

25500697 B0 0223

### Safety Messages for Installers of Warning Light Equipment

People's lives depend on your safe installation of our products. It is important to read, understand and follow all instructions shipped with the products. Listed below are some other important safety instructions and precautions you should follow:

- To properly install this light, you must have a good understanding of automotive electrical procedures and systems, along with proficiency in the installation and use of safety warning equipment.
- Do not install equipment or route wiring in the deployment path of an airbag.
- If a vehicle seat is temporarily removed, verify with the vehicle manufacturer if the seat needs to be recalibrated for proper airbag deployment.
- When drilling into a vehicle structure, ensure that both sides of the surface are clear of anything that could be damaged.
- Locate the light control so the VEHICLE and CONTROL can be operated safely under all driving conditions.
- Do not attempt to activate or deactivate the light control while driving in a hazardous situation.
- Frequently inspect the light to ensure that it is operating properly and that it is securely attached to the vehicle.
- This product contains high-intensity LEDs. Do not stare directly into the lights at a close range, or permanent damage to your eyesight may occur.
- Refer to the instructions packed with related products for additional precautions and information.
- File these instructions in a safe place and refer to them when maintaining and/or reinstalling the product.

Failure to follow all safety precautions and instructions may result in property damage, serious injury, or death.

**Table 1 Mounting kit contents**

| DS Qty. | PS Qty | Description                                       | Part Number   | Item No |
|---------|--------|---|---------------|---------|
| 1       | -      | 20FPIU Driver Side D-Pillar Light Bar Assembly    | 861303635B-DS | 1       |
| -       | 1      | 20FPIU Passenger Side D-Pillar Light Bar Assembly | 861303635B-PS | NS      |
| 2       | 2      | Cable Tie Swivel Mount                            | 150166A       | 2       |
| 3       | 3      | 4.29-inch White Cable Tie                         | 150A109       | NS      |
| 1       | 1      | 3M® Tape Primer                                   | R0001105A     | NS      |
| 2       | 2      | #8 Torx Thread-Forming Screw                      | 70001477A-08  | 3       |
| 1       | 1      | Alcohol Prep Pad                                  | 77701201A     | NS      |
| 1       | 1      | 0.38-inch ID Grommet                              | 77701321A     | NS      |
| 1       | 1      | Expansion Module D-Pillar LB Wire Assembly        | 17502542A     | NS      |

Figure 1 Exploded view with item numbers

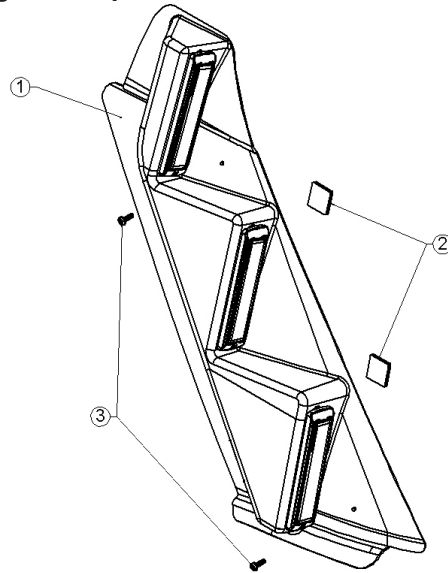

### Installing the D-Pillar Light Bar

**⚠ WARNING**

**AIRBAG DEPLOYMENT:** Do not install equipment or route wiring in the deployment path of an airbag. Failure to observe this warning will reduce the effectiveness of the airbag or potentially dislodge the equipment, causing serious injury or death.

**IMPORTANT:** Plan all cable routing before the installation.

To install the light bar:

1. Clean the surface of the vehicle in the location where the adhesive tape comes into contact with the vehicle. Alcohol prep pads are included for this. Prime this area with the included 3M<sup>®</sup> primer. See Figure 2.

Figure 2 Clean and prime

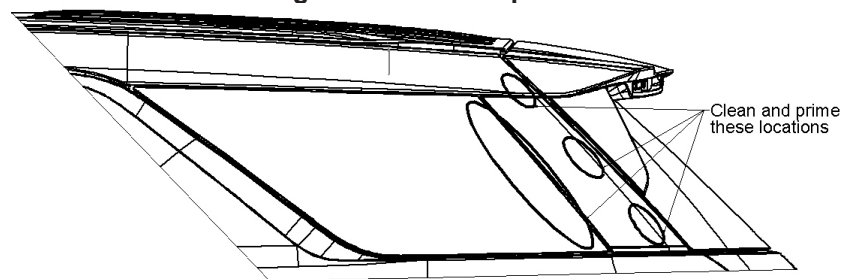

**NOTICE**

**DRILLING PRECAUTIONS:** When drilling holes, check the area you are drilling into to ensure that you do not damage vehicle components. All drilled holes should be deburred, and all sharp edges should be smoothed. All wire routings going through drilled holes should be protected by a grommet or convolute/split loom tubing.

## Installing the 2020 Ford Police Interceptor Utility D-Pillar Light Bar

2. Mark the hole location using the dimensions in Figure 3 for the wire harness to pass through the vehicle's body. Drill a 1/2-inch hole and grommet the hole with the included grommet.

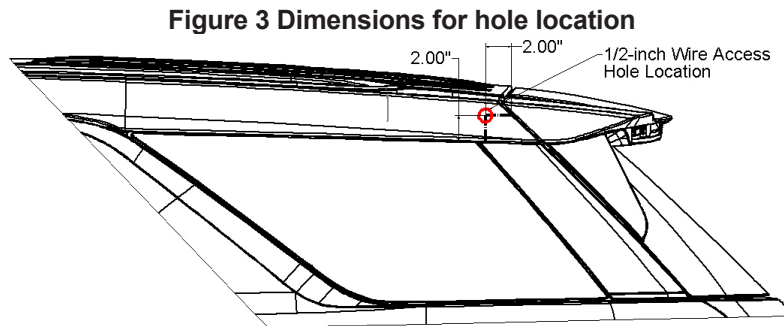

3. Feed the blunt cut end of the wire harness into the vehicle from the outside until there is only enough slack left to connect the harness to the light heads. Connect the wire harness to the light heads. The end connector on the wire harness connects to the bottom light head, the middle connector to the middle light head, and the last connector to the top light head.
4. Test the lights for proper operation.
5. Peel the backing off the cable tie mounts (Item #2) and place them according to Figure 4. Secure the wires to the cable tie mounts using the supplied cable ties. Be sure to secure the wires so that the connectors can be pulled through the shroud to replace a light head if they were to fail. Apply RTV or similar sealant to the location where the wire harness passes through the vehicle.

**Figure 4 Cable tie mount locations**

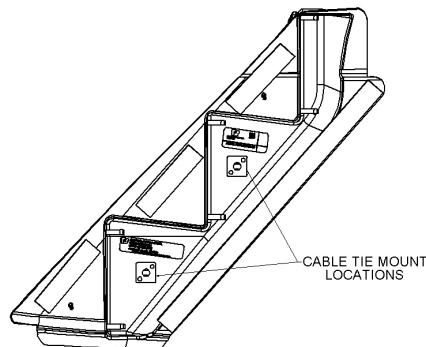

6. Peel the backing of the VHB tape on the shroud assembly, align it to the vehicle, and press it down.
7. Using a No. 29 drill bit (0.136-inch), drill the two holes in the vehicle's D-pillar in the locations of the existing holes of the shroud.
8. Using a T20 torx driver, screw in the supplied #8 thread-forming screws into the previously drilled holes. Do not overtighten the screws.
9. Repeat steps 1-8 for the opposite side.

### **⚠ WARNING**

**LIGHT HAZARD:** To be an effective warning device, an emergency warning system produces bright light that can be hazardous to your eyesight when viewed at a close range. Do not stare directly into the lights at a close range, or permanent damage to your eyesight may occur.

## **Getting Technical Support**

For technical support, please contact:

Federal Signal Corporation  
Service Department  
Phone: 1-800-433-9132  
Email: empSERVICEINFO@fedSIG.com

## **Getting Repair Service**

The Federal Signal factory provides technical assistance with any problems that cannot be handled locally. Any product returned to Federal Signal for service, inspection, or repair must be accompanied by a Return Material Authorization (RMA). Obtain an RMA from a local Distributor or Manufacturer's Representative. Provide a brief explanation of the service requested or the nature of the malfunction.

Address all communications and shipments to the following:

Federal Signal Corporation  
Service Department  
2645 Federal Signal Dr.  
University Park, IL 60484-3167

## **Limited Warranty**

This product is subject to and covered by a limited warranty, a copy of which can be found at [www.fedSIG.com/SSG-Warranty](http://www.fedSIG.com/SSG-Warranty). A copy of this limited warranty can also be obtained by written request to Federal Signal Corporation, 2645 Federal Signal Drive, University Park, IL 60484, email to [info@fedSIG.com](mailto:info@fedSIG.com) or call +1 708-534-3400.

This limited warranty is in lieu of all other warranties, express or implied, contractual or statutory, including, but not limited to the warranty of merchantability, warranty of fitness for a particular purpose and any warranty against failure of its essential purpose.



**FEDERAL SIGNAL**  
Safety and Security Systems

2645 Federal Signal Drive  
University Park, Illinois 60484-3167

[www.fedSIG.com](http://www.fedSIG.com)

Customer Support  
Police/Fire-EMS: 800-264-3578 • +1 708 534-3400  
Work Truck: 800-824-0254 • +1 708 534-3400  
Technical Support: 800-433-9132 • +1 708 534-3400

© Copyright 2021-2023 Federal Signal Corporation  
All product names or trademarks are properties of their respective owners.