

2561518 A1 0820

Safety Message to Installers and Service Personnel of Emergency Vehicle Safety Equipment

⚠ WARNING

People's lives depend on your proper installation and servicing of Federal products. It is important to read and follow all instructions shipped with the products. Listed below are some other important safety instructions and precautions you should follow.

- To properly install this siren, you must have a good understanding of automotive electrical procedures and systems, along with proficiency in the installation and use of safety warning equipment.
- All effective sirens and horns produce loud sounds (120 dB) that may cause permanent hearing loss. Always minimize your exposure to siren sound and wear hearing protection. Do not sound the siren indoors or in enclosed areas where you and others will be exposed to the sound.
- Install the speaker(s) as far forward on the vehicle as possible, in a location that provides maximum signaling effectiveness and minimizes the sound reaching the vehicle's occupants. Refer to the National Institute of Justice guide 500-00 for further information.
- When drilling into a vehicle structure, ensure that both sides of the surface are clear of anything that could be damaged. All drilled holes should be deburred and all sharp edges should be smoothed. All wires going through drilled holes should be protected by a grommet or convolute/split-loom tubing. Additionally, all exterior drilled holes must be sealed with Motorcraft seam sealer T-A-2-B or equivalent to prevent the potential exposure to carbon monoxide or other potentially harmful fumes. Failure to observe this warning could cause serious injury or death.
- Locate the siren controls so the VEHICLE and CONTROLS can be operated safely under all driving conditions.
- After installation and testing are complete, provide a copy of this instruction sheet to all operating personnel.
- File these instructions in a safe place and refer to them when maintaining and/or reinstalling the product.

Failure to follow all safety precautions and instructions may result in property damage, serious injury, or death to you or others.

Introduction

This instruction sheet provides directions for installation of the 8280065B-K Q-Siren Clutch Kit.

Unpacking the Product

After unpacking the product, inspect it for damage that may have occurred in transit. If it has been damaged, do not attempt to install or operate it. File a claim immediately with the carrier, stating the extent of the damage. **Failure to identify damage before installation could lead to the rejection of any claim.** Carefully check all envelopes, shipping labels, and tags before removing or destroying them. Ensure that the parts listed in Table 1 are included in the package. If you are missing any parts, contact Federal Signal Customer Support at 1-800-264-3578, 7 a.m. to 5 p.m., Monday through Friday (CT).

Table 1 Kit Contents List

Qty	Description	Part Number
1	Rotor Assembly	8280A065
2	Spring Washers	7074A054
1	Flat Washer	7072A140
1	Lock Nut	7058A036

Installing the Clutch Kit

⚠ WARNING

Electronically controlled transmissions may malfunction during operation of this siren. Consult the vehicle manufacturer BEFORE installing this siren in vehicles equipped with electronically controlled transmissions.

⚠ WARNING

All effective sirens and horns produce loud sounds (120 dB) that may cause permanent hearing loss. Always minimize your exposure to siren sound and wear hearing protection. Do not sound the siren indoors or in enclosed areas where you and others will be exposed to the sound.

⚠ WARNING

Any attachment to the Q-Siren or other alteration of the product may reduce its ability to warn and may interfere with the Q-Siren's ability to meet applicable industry standards. Federal Signal does not recommend or approve the use of any sound focusing device or other attachments to the Q-Siren. The unauthorized use of a sound focusing device or other attachment could result in serious injury or death.

To install the clutch kit:

1. Disconnect power to the siren at the positive battery terminal.
2. Remove and retain the four screws that secure the grille to the siren. Remove the grille.
3. Remove and retain the three screws that secure the chromed motor housing to the siren. Remove the motor housing.
4. Remove and retain the three screws that secure the clutch cap on the front of the siren.
5. Using an appropriate wrench, hold the motor shaft at the rear of the siren. While holding the motor shaft, loosen the lock nut on the front of the motor shaft. Remove and discard the lock nut and washers from the front of the motor shaft.
6. Remove the clutch assembly.
7. Pull the rotor assembly out and retain it for return to the factory.
8. Install the new rotor assembly with the clutch assembly facing forward.
9. Install the washers (flat washer first, then the spring washers) and lock nut on the front of the motor shaft as shown in Figure 1.
10. Torque the lock nut to 35-40 ft-lb.
11. Reinstall the clutch cap, motor housing, and grille on the siren.

12. Reconnect power to the siren at the positive battery terminal and test for proper operation.

Figure 1 Diagram

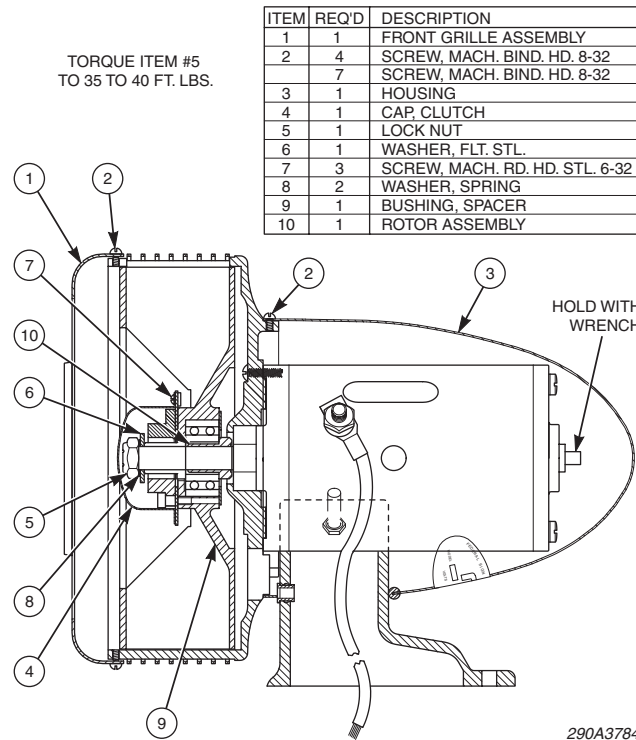

Maintaining the Unit

⚠ WARNING

SHOCK HAZARD: Disconnect the battery terminals before performing any maintenance on the unit to prevent accidental activation of the siren and possible electric shock.

NOTICE

The use of cleaning agents such as strong detergents, solvents, petroleum products, etc. can damage the chrome plated surfaces.

Use a mild soap and water solution and a soft rag to clean the chrome plated parts. Should fine scratches or a haze appear on the chrome parts, they can usually be removed with a non-abrasive, high quality, one-step, automotive paste cleaner/wax and a soft cloth.

Getting Technical Support

For technical support, please contact:

Federal Signal Corporation
 Service Department
 Phone: 1-800-433-9132
 Email: emp-service-info@fedsig.com

Getting Repair Service

The Federal Signal factory provides technical assistance with any problems that cannot be handled locally. Any product returned to Federal Signal for service, inspection, or repair must be accompanied by a Return Material Authorization (RMA). Obtain a RMA from a local Distributor or Manufacturer's Representative. Provide a brief explanation of the service requested or the nature of the malfunction.

Address all communications and shipments to the following:

Federal Signal Corporation
Service Department
2645 Federal Signal Dr.
University Park, IL 60484-3167

Limited Warranty

This product is subject to and covered by a limited warranty, a copy of which can be found at www.fedsig.com/SSG-Warranty. A copy of this limited warranty can also be obtained by written request to Federal Signal Corporation, 2645 Federal Signal Drive, University Park, IL 60484, email to info@fedsig.com or call +1 708-534-3400.

This limited warranty is in lieu of all other warranties, express or implied, contractual or statutory, including, but not limited to the warranty of merchantability, warranty of fitness for a particular purpose and any warranty against failure of its essential purpose.



2645 Federal Signal Drive
University Park, Illinois 60484-3167

www.fedsig.com

Customer Support

Police/Fire-EMS: 800-264-3578 • +1 708 534-3400

Work Truck: 800-824-0254 • +1 708 534-3400

Technical Support: 800-433-9132 • +1 708 534-3400

© Copyright 1999-2020 Federal Signal Corporation