

**Safety Messages to Installers**

25500417A Rev. A0 717

**⚠ WARNING**

People's lives depend on your proper installation and servicing of Federal Signal products. It is important to read and follow the instructions shipped with this product. Listed below are some other important safety instructions and precautions you should follow:

- To properly install the lighting system, you must have a good understanding of automotive systems.
- To avoid a battery explosion, always disconnect the negative battery cable first and reconnect it last. Avoid causing a spark when connecting near or to the battery. The gases produced by a battery can cause a battery explosion that could result in vehicle damage and serious injury.
- Do not install equipment or route wiring in the deployment path of an airbag. Failure to observe this warning will reduce the effectiveness of the airbag or potentially dislodge the equipment, causing serious injury or death.
- If a vehicle seat is temporarily removed, verify with the vehicle manufacturer if the seat needs to be recalibrated for proper airbag deployment.
- You should frequently inspect the light system to ensure that it is operating properly and that it is securely attached to the vehicle.
- Do not stare directly into the lights at a close range or permanent damage to your eyesight may occur.

Failure to follow all precautions and instructions may result in property damage, serious injury, or death.

## Installing the COMINT5 LED Compartment Light

**NOTE:** No. 6 mounting screws and a 5 A fuse and fuseholder are recommended.

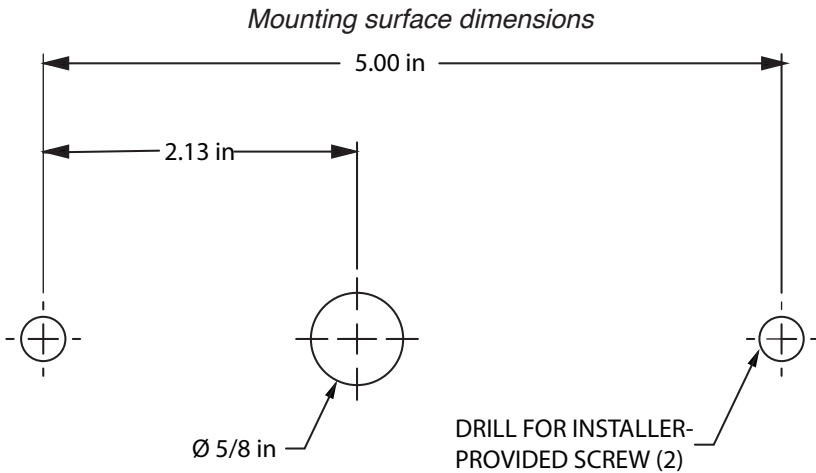

### **⚠ WARNING**

**AIRBAG DEPLOYMENT:** Do not install equipment or route wiring in the deployment of an airbag. Failure to observe this warning will reduce the effectiveness of the airbag or potentially dislodge the equipment, causing serious injury or death.

To install the light:

1. Mark three holes at the mounting location.

### **NOTICE**

**DRILLING PRECAUTION:** Check the area into which you are drilling to be sure you do not damage vehicle components while drilling. All drilled holes should be deburred and all sharp edges should be smoothed. All wire routings going through drilled holes should be protected by a grommet or convolute/split loom

2. Drill a 5/8 in hole at the wire routing location.
3. Drill pilot holes for the mounting screws.
4. Smooth and deburr the holes.

5. Insert a grommet in the wire routing hole and pass the wires through the grommet.
6. Install a user-supplied 5 A fuse and fuseholder as close as possible to the power source.
7. Connect the wires to a switched power source:  
**BLACK** is positive +12 Vdc.  
**WHITE** is ground (-).
8. Secure the light to the mounting surface.

**⚠ WARNING**

***LIGHT HAZARD: To be an effective warning device, an emergency warning system produces bright light that can be hazardous to your eyesight when viewed at close range. Do not stare directly into the lights at a close range or permanent damage to your eyesight may occur.***

9. Test the light for proper operation.

## **Getting Technical Support and Service**

The Federal Signal factory provides technical assistance with any problems that cannot be handled locally. Any units returned to Federal Signal for service, inspection, or repair must be accompanied by a Return Material Authorization (RMA). Obtain a RMA from a local Distributor or Manufacturer's Representative. Please provide a brief explanation of the service requested, or the nature of the malfunction.

For technical support and service, visit:

<https://www.fedsig.com/technical-support>

<https://www.fedsig.com/service-centers>

## Limited Warranty

This product is subject to and covered by a limited warranty, a copy of which can be found at [www.fedsig.com/SSG-Warranty](http://www.fedsig.com/SSG-Warranty). A copy of this limited warranty can also be obtained by written request to Federal Signal Corporation, 2645 Federal Signal Drive, University Park, IL 60484, email to [info@fedsig.com](mailto:info@fedsig.com) or call +1 708-534-3400.

This limited warranty is in lieu of all other warranties, express or implied, contractual or statutory, including, but not limited to the warranty of merchantability, warranty of fitness for a particular purpose and any warranty against failure of its essential purpose.



**FEDERAL SIGNAL**  
Safety and Security Systems

2645 Federal Signal Drive  
University Park, Illinois 60484

[www.fedsig.com](http://www.fedsig.com)

Customer Support

Police/Fire-EMS: 800-264-3578 • +1 708 534-3400

Work Truck: 800-824-0254 • +1 708 534-3400

Technical Support 800-433-9132 • +1 708 534-3400