

# Directional Speaker Array

Models: DSA2, DSA4, DSA6



---

## ***Description, Specifications, and Installation Manual***

## Limited Warranty

This product is subject to and covered by a limited warranty, a copy of which can be found at [www.fedsig.com/SSG-Warranty](http://www.fedsig.com/SSG-Warranty). A copy of this limited warranty can also be obtained by written request to Federal Signal Corporation, 2645 Federal Signal Drive, University Park, IL 60484, email to [info@fedsig.com](mailto:info@fedsig.com) or call +1 708-534-3400.

This limited warranty is in lieu of all other warranties, express or implied, contractual or statutory, including, but not limited to the warranty of merchantability, warranty of fitness for a particular purpose and any warranty against failure of its essential purpose.



**FEDERAL SIGNAL**  
Safety and Security Systems

2645 Federal Signal Drive  
University Park, Illinois 60484

[www.fedsig.com](http://www.fedsig.com)

Customer Support            800-548-7229 • +1 708 534-3400

Technical Support            800-524-3021 • +1 708 534-3400

All product names or trademarks are properties of their respective owners.

---

## Contents

<b>Safety Messages</b> .....	<b>5</b>
<b>General Description</b> .....	<b>7</b>
Introduction .....	7
Features.....	8
<b>Specifications</b> .....	<b>8</b>
<b>Wiring Options</b> .....	<b>10</b>
<b>Installation Instructions</b> .....	<b>11</b>
Determine a Suitable Location.....	11
Installing the Sirens.....	12
Installation Bracket Options .....	13
Pole Installation.....	17
Wood Utility Pole Installation .....	18
Concrete or Metal Pole Installation.....	18
Wall Mount Applications.....	22
<b>Getting Service</b> .....	<b>24</b>
<b>Appendix A DSA Drawings</b> .....	<b>25</b>

### Tables

<b>Table 1 DSA Specifications</b> .....	<b>8</b>
<b>Table 2 Mounting Configurations and Horizontal Coverage</b> .....	<b>8</b>
<b>Table 3 General Specifications</b> .....	<b>9</b>
<b>Table 4 Wind Loading</b> .....	<b>9</b>
<b>Table 5 Mounting Kits</b> .....	<b>9</b>
<b>Table 6 Bracket Options</b> .....	<b>13</b>
<b>Table 7 Bracket Options for Size of Pole</b> .....	<b>18</b>
<b>Table 8 Replacement Parts</b> .....	<b>24</b>

---

## Figures

Figure 1 Two DSA4s with a DSAMK4 bracket.....	7
Figure 2 Various DSA Configurations .....	10
Figure 3 Top of pole mount using DSAMK4.....	14
Figure 4 Large Pole Mount .....	14
Figure 5 Bracket I-IP100-PMW Bracket Picture .....	15
Figure 6 Bracket I-IP100-PMW Drawing.....	15
Figure 7 Bracket I-IP100-PM Picture .....	16
Figure 8 Bracket I-IP100-PM Drawing.....	16
Figure 9 Typical Pole Installation.....	17
Figure 10 DSAMK1 Bracket Dimensions.....	19
Figure 11 DSAMK1 Bracket Picture .....	19
Figure 12 DSAMKSPB45 Bracket Dimensions .....	20
Figure 13 DSAMKSPB45 Bracket Picture.....	20
Figure 14 DSAMKSPB23 Bracket Dimensions .....	21
Figure 15 Top view of DSAMK4 bolt hole pattern.....	21
Figure 16 Wall Mount Configuration .....	22
Figure 17 DSAMKSP Mounting Kit.....	23
Figure 18 DSA Assembly Drawing .....	25
Figure 19 Wiring Options.....	26
Figure 20 Wiring Options Continued.....	27

---

## Safety Messages

**⚠ WARNING**

It is important to follow all instructions shipped with this product. This device is to be installed by trained personnel who are thoroughly familiar with the country electric codes and will follow these guidelines as well as local codes and ordinances, including any state or local-noise control ordinances.

Listed below are important safety instructions and precautions you should follow:

**Important Notice**

Federal Signal reserves the right to make changes to devices and specifications detailed in the manual at any time in order to improve reliability, function or design. The information in this manual has been carefully checked and is believed to be accurate; however, no responsibility is assumed for any inaccuracies.

**Publications**

Federal Signal recommends the following publications from the Federal Emergency Management Agency for assistance with planning an outdoor warning system:

- The “Outdoor Warning Guide” (CPG 1-17)
- “Civil Preparedness, Principles of Warning” (CPG 1-14)
- FEMA-REP-1, Appendix 3 (Nuclear Plant Guideline)
- FEMA-REP-10 (Nuclear Plant Guideline).

**Planning**

- If suitable warning equipment is not selected, the installation site for the siren is not selected properly or the siren is not installed properly, it may not produce the intended optimum audible warning. Follow Federal Emergency Management Agency (FEMA) recommendations.
- If sirens are not activated in a timely manner when an emergency condition exists, they cannot provide the intended audible warning. It is imperative that knowledgeable people, who are provided with the necessary information, be available at all times to authorize activation.
- When sirens are used out of doors, people indoors may not be able to hear the warning signals. Separate warning devices or procedures may be needed to warn people indoors effectively.
- The sound output of sirens is capable of causing permanent hearing damage. To prevent excessive exposure, carefully plan siren placement, post warnings, and restrict access to areas near sirens. Review and comply with any local or state noise control ordinances as well as OSHA noise exposure regulations and guidelines.
- Activating the sirens may not result in people taking the desired actions if those to be warned are not properly trained about the meaning of siren sounds. Siren users should follow FEMA recommendations and instruct those to be warned of corrective actions to be taken.

## Safety Messages

---

- After installation, service, or maintenance, test the siren system to confirm that it is operating properly. Test the system regularly to confirm that it will be operational in an emergency.
- If future service and operating personnel do not have these instructions to refer to, the siren system may not provide the intended audible warning and service personnel may be exposed to death, permanent hearing loss, or other bodily injury. File these instructions in a safe place and refer to them periodically. Give a copy of these instructions to new recruits and trainees. Also give a copy to anyone who is going to service or repair the siren.

### Installation and Service

- Electrocution or severe personal injury can occur when performing various installation and service functions such as making electrical connections, drilling holes, or lifting equipment. Therefore, only experienced electricians should install this product in accordance with national, state and any other electrical codes having jurisdiction. Perform all work under the direction of the installation or service crew safety foreman.
- The sound output of sirens is capable of causing permanent hearing damage. To prevent excessive exposure, carefully plan siren placement, post warnings, and restrict access to areas near the sirens. Sirens may be operated from remote control points. Whenever possible, disconnect all siren power, including batteries, before working near the siren. Review and comply with any local or state noise control ordinances as well as OSHA noise exposure regulations and guidelines.
- After installation or service, test the siren system to confirm that it is operating properly. Test the system regularly to confirm that it will be operational in an emergency.
- If future service personnel do not have these warnings and all other instructions shipped with the equipment to refer to, the siren system may not provide the intended audible warning and service personnel may be exposed to death, permanent hearing loss, or other bodily injury. File these instructions in a safe place and refer to them periodically. Give a copy of these instructions to new recruits and trainees. Also give a copy to anyone who is going to service or repair the sirens.

### Operation

Failure to understand the capabilities and limitations of your siren system could result in permanent hearing loss, other serious injuries, or death to persons too close to the sirens when you activate them or to those you need to warn. Carefully read and thoroughly understand all safety notices in this manual and all operations-related items in all instruction manuals shipped with the equipment. Thoroughly discuss all contingency plans with those responsible for warning people in your community, company, or jurisdiction.

***Read and understand the information contained in this manual before attempting to install or service the siren.***

Pay careful attention to notices located on the equipment.

---

## General Description

### Introduction

This manual describes the features, specifications, and installation of the Directional Speaker Array (DSA). See the UltraVoice Electronic Siren Controller Manual for operating instructions.

The DSA is a flexible and adaptable high-powered speaker array. It can be configured in many ways to customize your site's needs. Let Federal Signal design your DSA configuration. Contact Federal Signal through pre-sales or contact your local sales representative.

The DSA is a flexible family of high-powered speakers capable of providing audible signals (tone or voice) over a large area to satisfy varying signaling needs in multiple directions. A typical installation consists of between one and four arrays designed to be powered by a Federal Signal UltraVoice Controller. A highly efficient design enables the speakers to produce a high sound level while making moderate demands on the power source. Each array can contain between two and six individual speakers. (Figure 1 shows two DSA4s with a DSAMK4 bracket.)

**Figure 1 Two DSA4s with a DSAMK4 bracket**



DSA speakers are comprised of fiberglass projectors and aluminum housings and stainless steel mounting brackets that include hardware for mounting the bracket to the speaker. Each speaker provides 100 watts of signaling power.

Each DSA2, DSA4, and DSA6 speaker array includes one DSAMK1 bracket. A DSA speaker requires two brackets for proper mounting. When mounting DSAs to poles, several brackets can be attached. These brackets provide secure mounting for a variety of applications. If mounting to a pole, see “Table 6 Bracket Options” on page 13.

## Specifications

---

Each array set covers one 90° quadrant. The dB(C) ratings at 100 feet on axis are shown below:

DSA2 111 dB(C)

DSA4 117 dB(C)

DSA6 121 dB(C)

The DSA provides excellent voice reproduction and, with the aid of the UltraVoice Controller, produces the following pre-programmed warning signals: Wail, Pulsed Steady, Pulsed Wail, Alternating Alert, Alternating Wail, and Westminster Chimes. The UltraVoice Controller can be networked and provide voice messages for clear instructions during emergency notifications.

## Features

The DSA has the following features:

- Maintenance Free
- Multiple mounting options available—wall, pole (wood or steel)
- Able to mount up to four speaker arrays per pole
- Each speaker contains multiple 100-watt drivers
- Provides excellent voice reproduction when used with the UltraVoice Controller
- Available in three models for a wide range of sound coverage

## Specifications

**Table 1 DSA Specifications**

Color	Black projectors and off-white housing
Paint type	TGIC polyester powder coat
Projector Type	Re-entrant
Frequency Response	200 to 2000 Hz
Operating temp range	-22°F to +140°F (-30°C to +60°C)
Humidity range	95% ± 2%

**Table 2 Mounting Configurations and Horizontal Coverage**

Single Unit	70°
Two Units:	
Side by Side at 90°	180°
Opposite Sides of pole at 180°	140° Collectively
Three adjacent sides at 90° to one another	210°
Four sides at 90° to one another	360°



**Table 3 General Specifications**

Specifications	DSA2	DSA2-1	DSA4	DSA4-1	DSA6	DSA6-1
Number of Speakers	2		4		6	
Watts	200		400		600	
Sound output per individual stack, dB(C) at 100 feet	111		117		121	
Effective Range at 70 dB(C)	1700 ft		2600 ft		3400 ft	
Height in inches	24.25		48.75		73.25	
Net Weight (lb)	43		95		125	
Cable Length	45 ft	94 ft	45 ft	94 ft	45 ft	94 ft
Power Requirements	One UV400 Amplifier Can support two DSA2s		One UV400 Amplifier		Two UV400 Amplifiers Three UV400s can support two DSA6s	

**Table 4 Wind Loading**

	DSA2	DSA4	DSA6
EPA at 40 feet	3.66 ft <sup>2</sup>	7.32 ft <sup>2</sup>	10.98 ft <sup>2</sup>
Wind Load (110 mph, 40 feet above ground)	189 lbf	404 lbf	626 lbf

**NOTE:** When calculating total power requirements, determine the total number of speakers needed in your installation, and divide the total by four. The result is the number of amplifiers required for your installation. If the result is not a whole number, then round up to the next whole number.

For example, if your site needs 1200 watts, then this is 12 speakers because each speaker provides 100 watts of signaling power.

Consider the following example:  
(12 speakers)/4 = 3 amplifiers.

This example shows that the power requirements are three 400-watt amplifiers.

**Table 5 Mounting Kits**

DSAMK1	Each DSA is shipped with one DSAMK1 bracket for wall mount applications. Order an additional DSAMK1 per DSA. See Figure 10.
DSAMK4	Mounting kit for one to four vertical stack(s) 90° apart.
DSAMKSP	Mounting kit for the top of steel poles that includes a 4.5-inch pole and brackets for one DSA.
DSAMKSPB45	Mounting kit for 4.5-inch steel pole. Includes two brackets, two u-bolts, and mounting hardware for one DSA2, DSA4, or DSA6 speaker. Federal Signal recommends using two I-IP100-PMW brackets. See Figure 6.
DSAMKSPB23	Mounting kit for 2.375-inch steel pole. Includes two brackets, two u-bolts, and mounting hardware for one DSA2, DSA4, or DSA6 speaker. Federal Signal recommends using two I-IP100-PM brackets. See Figure 8.

Figure 2 Various DSA Configurations

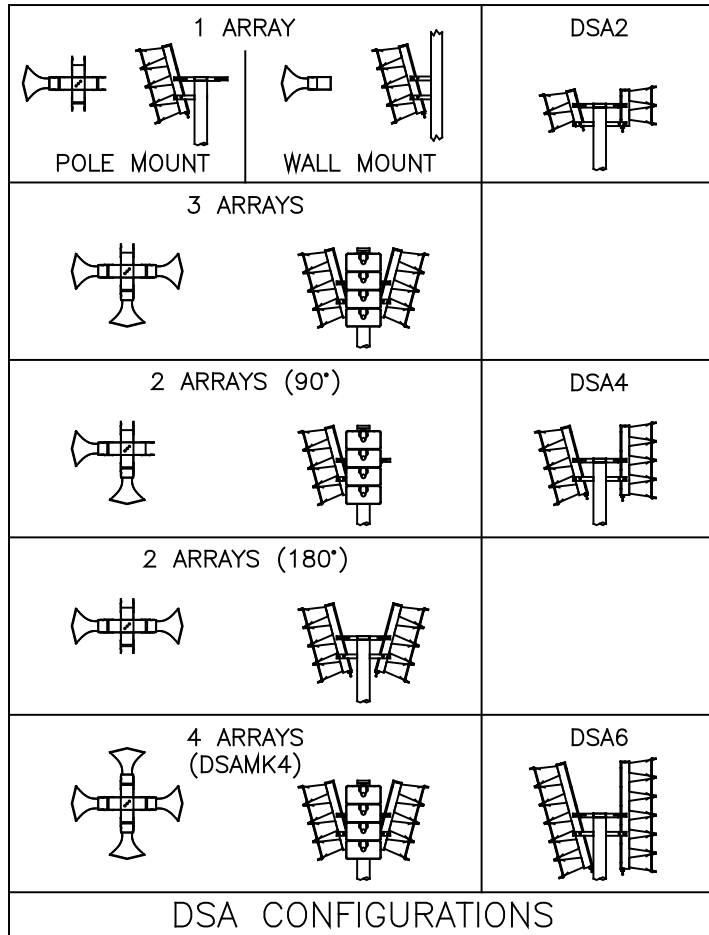

## Wiring Options

You can configure DSA speakers to address many different applications when used with UV Controllers. Typical installations involve one to four DSA speakers operated from a UV Controller. Equip the UV Controller with up to eight UV400 amplifiers. Each UV400 amplifier provides 400 watts. Also, each DSA is equipped with a four-conductor cable 45 feet or 94 feet in length. When installing DSA speakers with fewer than six speakers, tie off the unused connectors. Do not trim connectors. Use extra connectors, later, to add accessories or other speakers.

### DSA2 Wiring Options

A DSA2 speaker requires 200 watts of power, which uses 50% of a single UV400 amplifier. Use a single UV400 amplifier to power two DSA2s that are wired in parallel for a total power of 400 watts. A UV Controller equipped with eight UV400 amplifiers can power up to sixteen DSA2s. See “Figure 19 Wiring Options.”

### DSA4 Wiring Options

A DSA4 speaker requires 400 watts of power or a single UV400 amplifier. A UV Controller equipped with eight UV400 amplifiers can power up to eight DSA4s. See “Figure 19 Wiring Options.”

### DSA6 Wiring Options

A DSA6 speaker requires 600 W of power or two UV400 amplifiers, with one at 100% and the other at 50%. Equip a UV Controller with six UV400 amplifiers to power four DSA6s. Use the remaining two UV400 amplifiers for two DSA4s or other combinations up to 800 watts. See “Figure 20 Wiring Options Continued.”

### Mixing DSA Speakers Wiring Options

DSA4 speakers always use a single UV400 amplifier. You can mix DSA2 and DSA6 to use the UV400 amplifiers efficiently. When wiring different DSA speakers together, be careful to follow the wiring diagrams to ensure drivers are always in series or series/parallel arrangement. See Figures 19 and 20 for wiring examples.

## Installation Instructions

### Determine a Suitable Location

The information in this section provides guidelines to aid you in selecting installation sites that make the best possible use of the speaker array siren.

**⚠ WARNING**

***SOUND HAZARD: The sound output level of some DSA sirens is capable of causing permanent hearing damage. To prevent excessive exposure, carefully plan the placement of the sirens and post warnings.***

***Do not expose personnel to sound levels above 123 dBC.***

***When the sirens are used out of doors, people indoors may not be able to hear the warning signals. You may need separate warning devices or procedures to warn people indoors effectively.***

Careful consideration of the factors affecting the propagation of sound from the siren and the response of the human ear to the sound will optimize the ability of the siren to warn the community effectively.

The reduction of signal intensity as distance from the siren increases and the minimum desired signal level at the fringe of the area to be covered are important considerations when choosing a siren installation site. As the distance from the siren increases, sound level losses accumulate. These losses result from weather conditions, the terrain, obstructions in the sound path, the pitch of the sound, and the height of the siren.

Optimum sound propagation conditions occur when no obstructions exist in the sound path, the terrain is hard and flat, and the air is blowing away from the source. Under these conditions, you can expect a 6 dB loss per distance doubled. A loss per distance doubled of 10 dB is typically experienced because the atmosphere is rarely calm, terrain may not be flat, and buildings or other obstructions are frequently present in the sound path.

## Installation Instructions

---

Using a 10 dB per distance doubled loss factor, the following sound levels are predicted for the DSA6:

- 100 feet (30.5 m) the sound level is 121 dB
- 200 feet (61 m) the sound level is 111 dB
- 400 feet (122 m) the sound level is 101 dB
- 800 feet (244 m) the sound level is 91 dB

FEMA studies indicate typical ambient sound levels vary by location as follows:

- Industrial Areas: 70+ dBC
- Urban Areas: 60 dBC
- Rural Areas: 50 dBC

Optimum warning is obtained when the warning signal is at least 10 dB above ambient. Do not expose personnel to sound levels above 123 dBC.

Wind speed and direction often affect the propagation of sound from the siren. Consequently, prevailing wind direction may be a significant factor to consider when selecting the installation site(s) of a small, one or two site siren system. For example, if the prevailing wind is from the west, it may be desirable to install the siren toward the western edge of the area to be covered.

Other factors to consider when selecting the installation site(s) include the availability of suitable electrical power, the access to and ease of installation and maintenance, the height of surrounding obstructions, and security against vandalism.

## Installing the Sirens

### **⚠ DANGER**

***SHOCK HAZARD: Electrocutation or severe personal injury can occur when making electrical connections, drilling holes, or lifting equipment. Therefore, installation should be performed by experienced electricians following national and local codes.***

### **⚠ WARNING**

***SOUND HAZARD: The sound output level of some DSA sirens is capable of causing permanent hearing damage. To prevent excessive exposure, carefully plan the placement of sirens and post warnings.***

Most DSA siren installations are on poles. The arrays may also be installed on elevated vertical surfaces, such as walls, or flat horizontal surfaces, such as roofs.

A siren is typically installed 40 to 50 feet above the ground. If a DSA siren is installed at less than 40 feet above the ground, the sound intensity at close range may increase, but at the same time, the effective range of the siren may be reduced. Conversely, if the siren is located more than 50 feet above the ground, the siren’s effective range may increase, but the sound may skip over areas closer to the siren. These variables make it desirable to test the siren’s sound coverage at various heights and locations whenever possible.

**Installation Bracket Options**

Each DSA speaker array includes a DSAMK1, which is a wall mounting kit for one vertical stack that contains stainless steel brackets and mounting hardware. This bracket will become the lower bracket in your installation. (See Figure 3.) You can use all brackets on wood, concrete, or metal utility poles. Use brackets on the interior and exterior wall structures.

Use the following table for bracket options.

**Table 6 Bracket Options**

<b>Number of DSA or size of pole</b>	<b>Mounting Bracket for Installation</b>
Single DSA mounted on a vertical surface	Use a second DSAMK1 bracket. (See Figure 10.)
One to four DSAs installed on top of a wood pole with sirens directed every 90°	Use any of the following optional upper brackets: <ul style="list-style-type: none"> <li>• One DSAMK1 for each DSA.</li> <li>• One DSAMK4 for installation on the top of the pole.</li> </ul>
DSAs installed on 6 inches or larger pole	Use two DSAMKSPB45 and two I-IP100-PMW for each DSA. (See Figures 7 and 13.)
Top of pole mount for one to four DSA speakers	<ul style="list-style-type: none"> <li>• Use DSAMKSP, which includes a complete mounting assembly for the top of the pole and a 4.5-inch pole with brackets for one DSA speaker.</li> <li>• Use additional DSAMKSPB45 for each additional DSA. (See Figure 13.)</li> </ul>
4.5 inch steel pole mount	<ul style="list-style-type: none"> <li>• Use DSAMKSPB45 for mounting a DSA to a 4.5-inch or larger steel pole.</li> <li>• Use one DSAMKSPB45 and two I-IP100-PMW for each DSA2, DSA4, or DSA6.</li> <li>• Use an optional I-IP100-PMW to provide additional mounting rigidity.</li> </ul>
2-3/8 inch steel pole mount	<ul style="list-style-type: none"> <li>• Use DSAMKSPB23 for mounting a DSA to a 2-3/8 inch steel pole.</li> <li>• Use one DSAMKSPB23 and two I-IP100-PM for each DSA2, DSA4, or DSA6.</li> <li>• Use an optional I-IP100-PM to provide additional mounting rigidity.</li> </ul>

Figure 3 Top of pole mount using DSAMK4

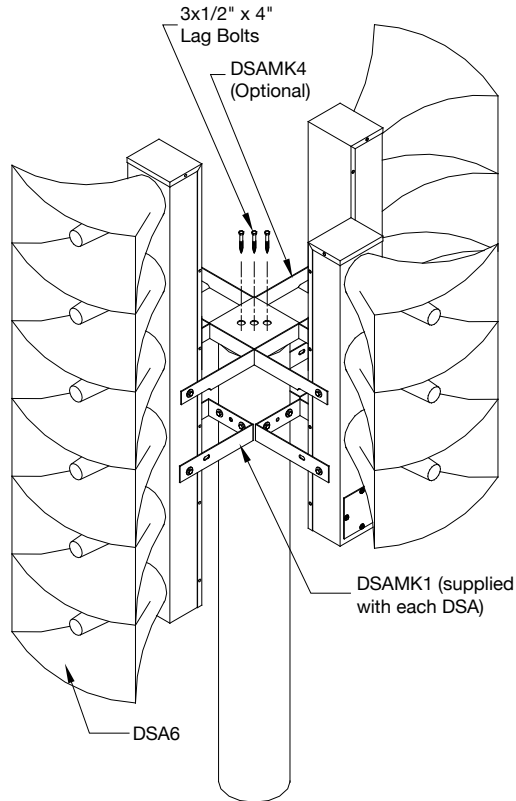
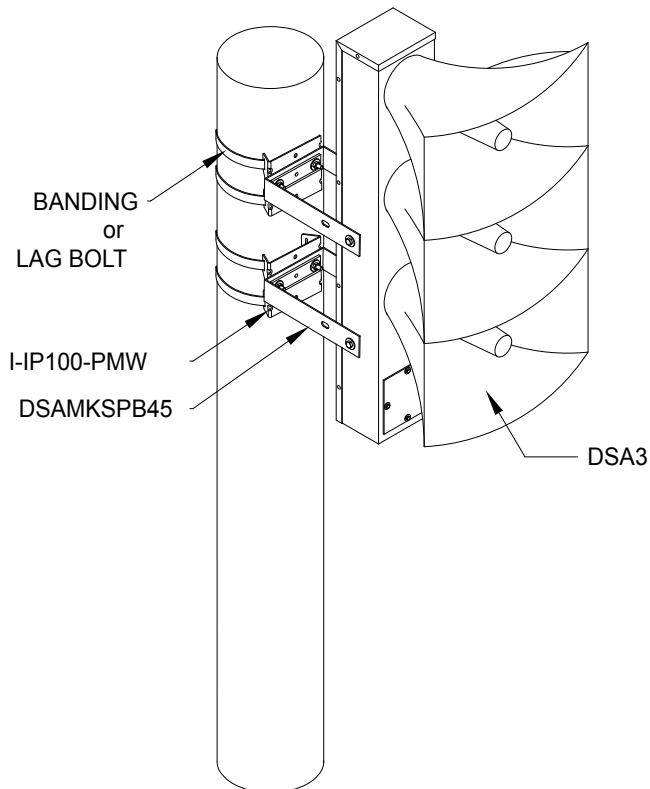

Figure 4 Large Pole Mount



**Figure 5 Bracket I-IP100-PMW Bracket Picture**



**Figure 6 Bracket I-IP100-PMW Drawing**

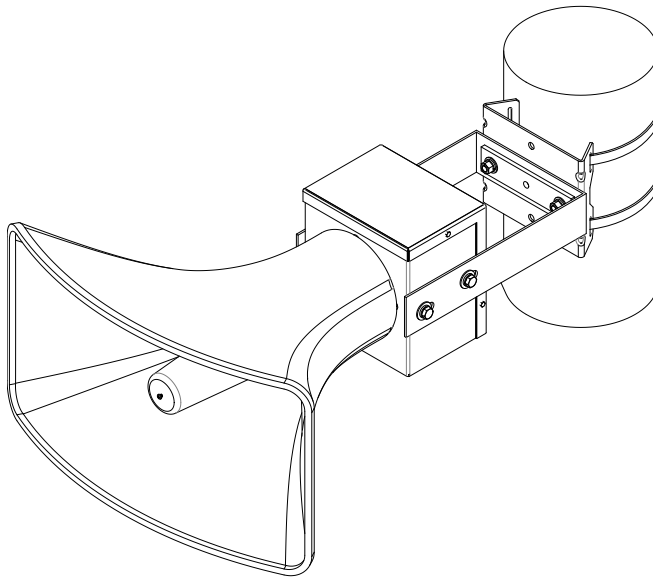

**Figure 7 Bracket I-IP100-PM Picture**



**Figure 8 Bracket I-IP100-PM Drawing**

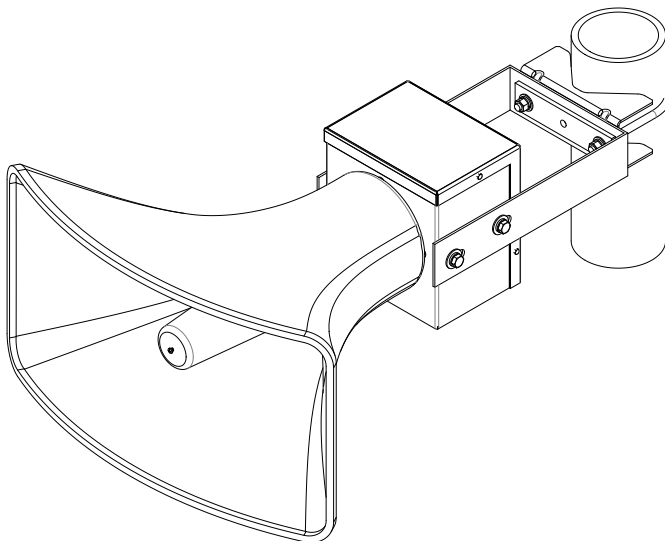



**Pole Installation**

Install a utility pole following national and local acceptable practices. Determine the number of arrays to be mounted and the direction in which the array(s) is/are to be orientated.

**Figure 9 Typical Pole Installation**

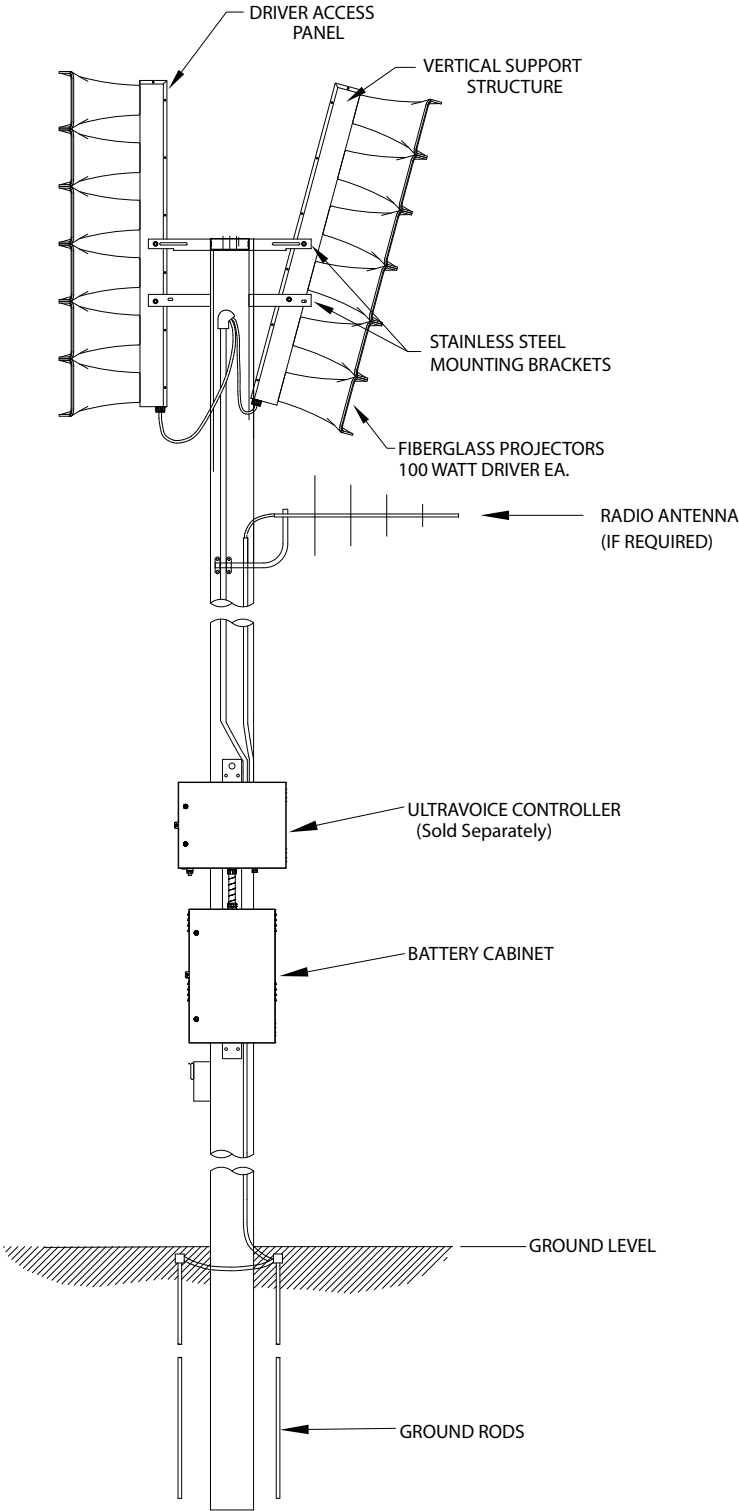

### **Wood Utility Pole Installation**

To install a wood utility pole:

1. Mount the upper DSA bracket, obtained as an option, at the top of the pole with the proper orientation. Secure the DSA bracket to the utility pole with three 1/2 by 4 inch long galvanized lag bolts and three 1/2 inch flat washers. (Bolts and washers are supplied by the installer.) See Figure 3.
2. Measure 12 inches down the pole from the center of the upper bracket to the point that will be at the center of the DSAMK1 bracket.
3. Align the lower DSAMK1 bracket so it is in vertical alignment with the upper bracket.
4. Mount the lower DSAMK1 bracket using three 1/2 by 4 inch long galvanized lag bolts and three 1/2 inch flat washers.
5. Remove and save the mounting bolts from the DSA.
6. Lift the array into position, with the cable coming out the bottom, and loosely secure it to the previously installed upper DSA bracket at the outermost bracket holes using the hardware previously removed.
7. Depending on how the array is mounted:
  - If the array is to be mounted facing a horizontal plane, attach it to the DSAMK1 lower bracket in the outermost bracket holes using the hardware previously removed.
  - If the array is to be mounted so that it is pitched downward at a 15° angle, attach it to the lower bracket at the innermost bracket holes using the previously removed hardware.
8. Tighten all array mounting bolts.

Repeat steps 1-8 for each array in the installation.

### **Concrete or Metal Pole Installation**

If the metal pole has a top of the pole plate, use the DSAMKSP to mount it to the pole's top. The DSAMKSP has all hardware to mount to the top of the pole and to mount one DSA. If additional DSA speakers are to be mounted, use the DSAMKSPB45 kit. You can use all brackets on wood, concrete, or metal utility poles.

**Table 7 Bracket Options for Size of Pole**

<b>Size of Pole</b>	<b>Mounting Bracket</b>
For poles 4.5 inches or larger	Use two I-IP100-PMW mounting brackets with banding and a DSAMKSPB45 kit
For poles between 2-1/2 and 4.5 inches	Use one DSAMKSPB45 kit and two I-IP100-PM
For poles 2-3/8 inches or smaller	Use one DSAMKSPB23 and two I-IP100-PM

Pay careful attention to the orientation of these attachments to the poles. Once in place, the speakers will project the loudest sounds in the directions that the brackets face.

When the installation requires the use of the DSAMK4 mounting bracket, you must make a circular plate and rigidly attach to the top of the pole. Figure 15 shows the required bolt-hole pattern for those brackets.

**NOTE:** The pole top mounting holes are at a 45° angle to the speakers' horizontal centerline.

The balance of the installation is similar to that for a wooden utility pole installation, except that the installer will provide grade 5 machine screws, washers, and nuts for the attachment of the siren brackets to the pole brackets.

The DSAMK1 drawing shows the bolt-hole pattern that the new bracket must be attached to. See Figure 10.

**Figure 10 DSAMK1 Bracket Dimensions**

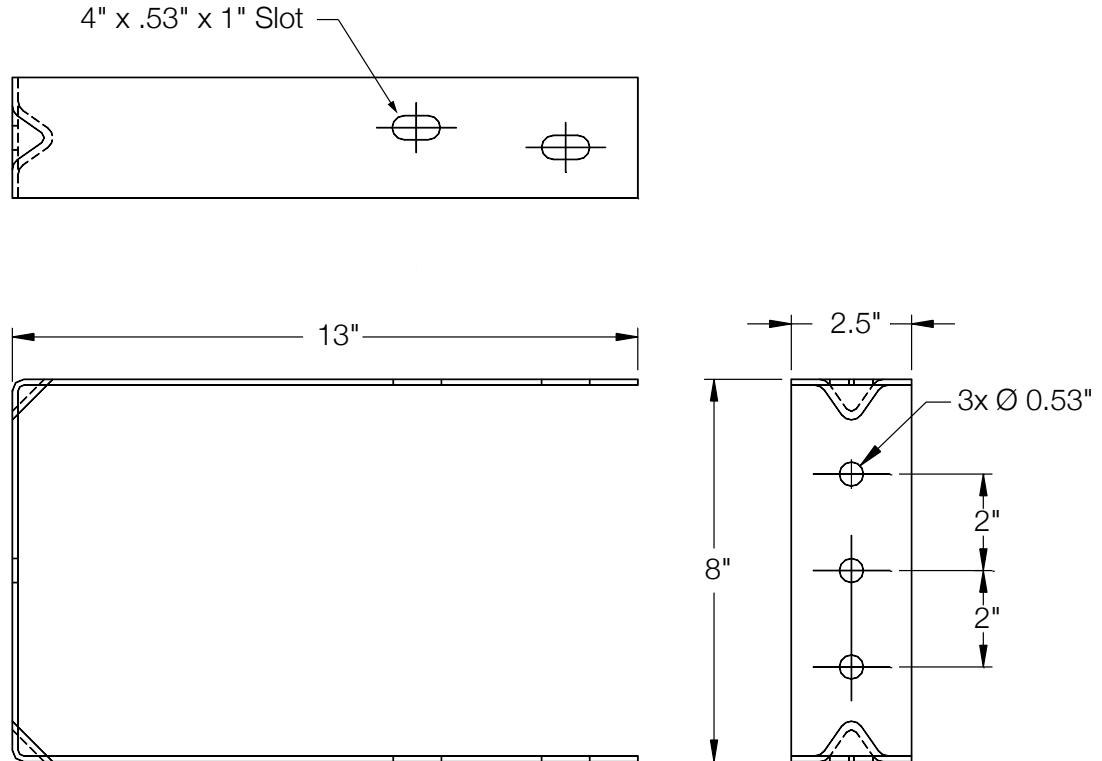

**Figure 11 DSAMK1 Bracket Picture**



Figure 12 DSAMKSPB45 Bracket Dimensions

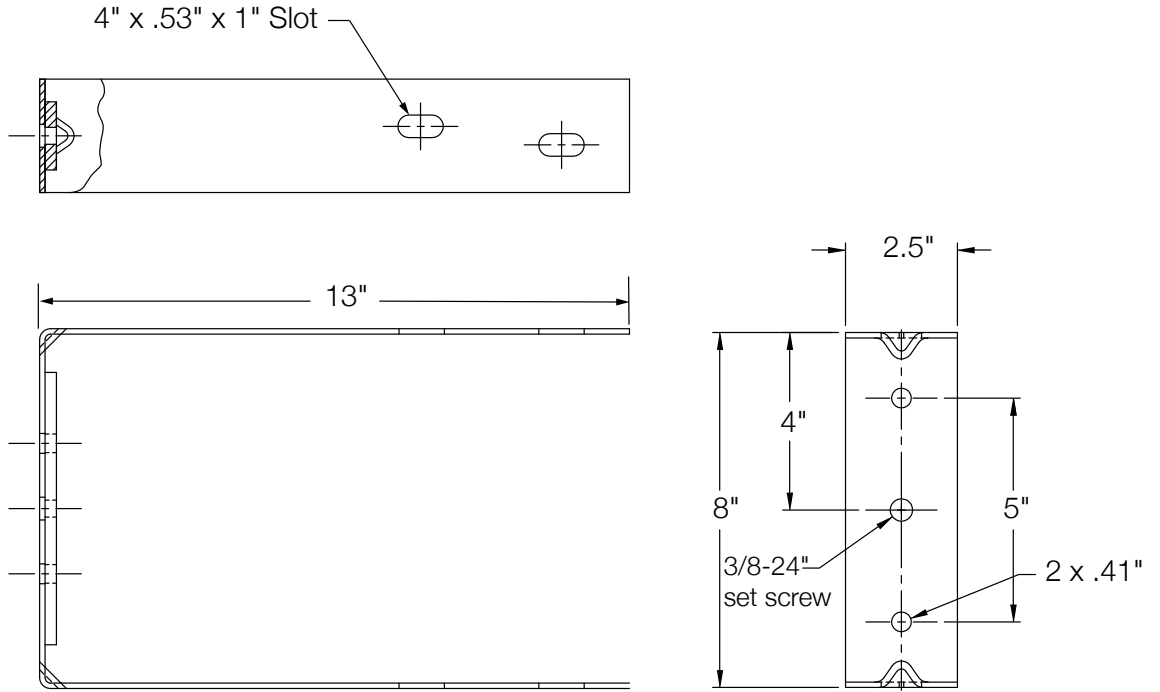

Figure 13 DSAMKSPB45 Bracket Picture



Figure 14 DSAMKSPB23 Bracket Dimensions

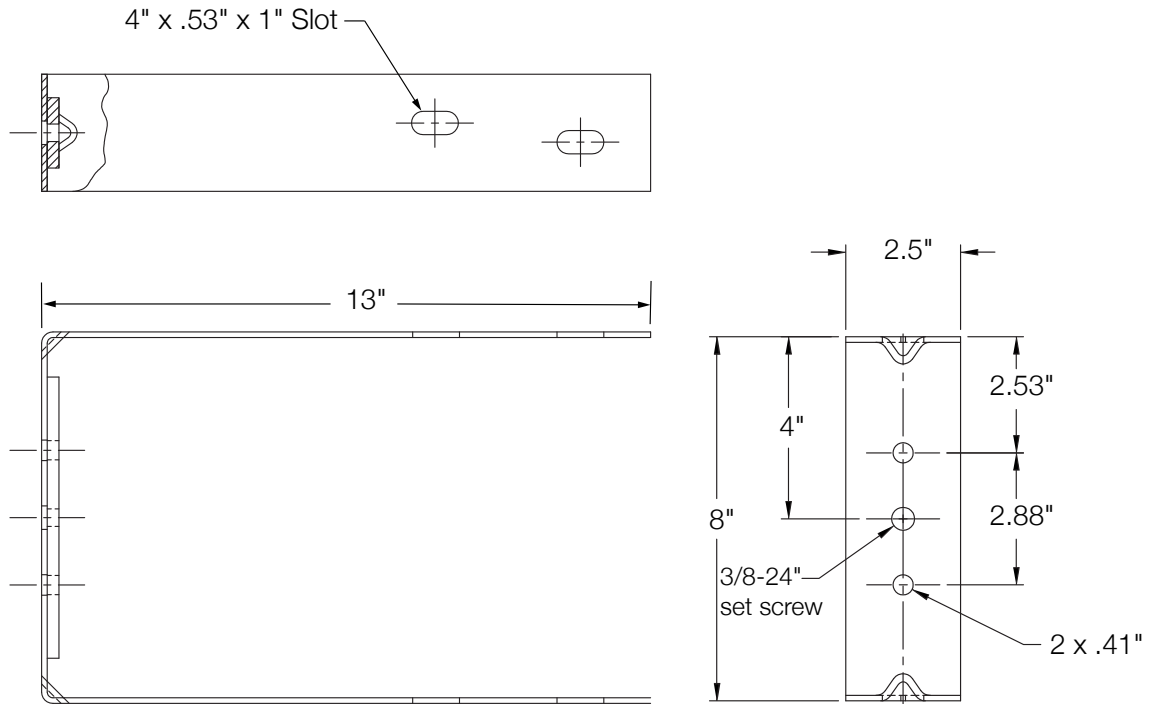
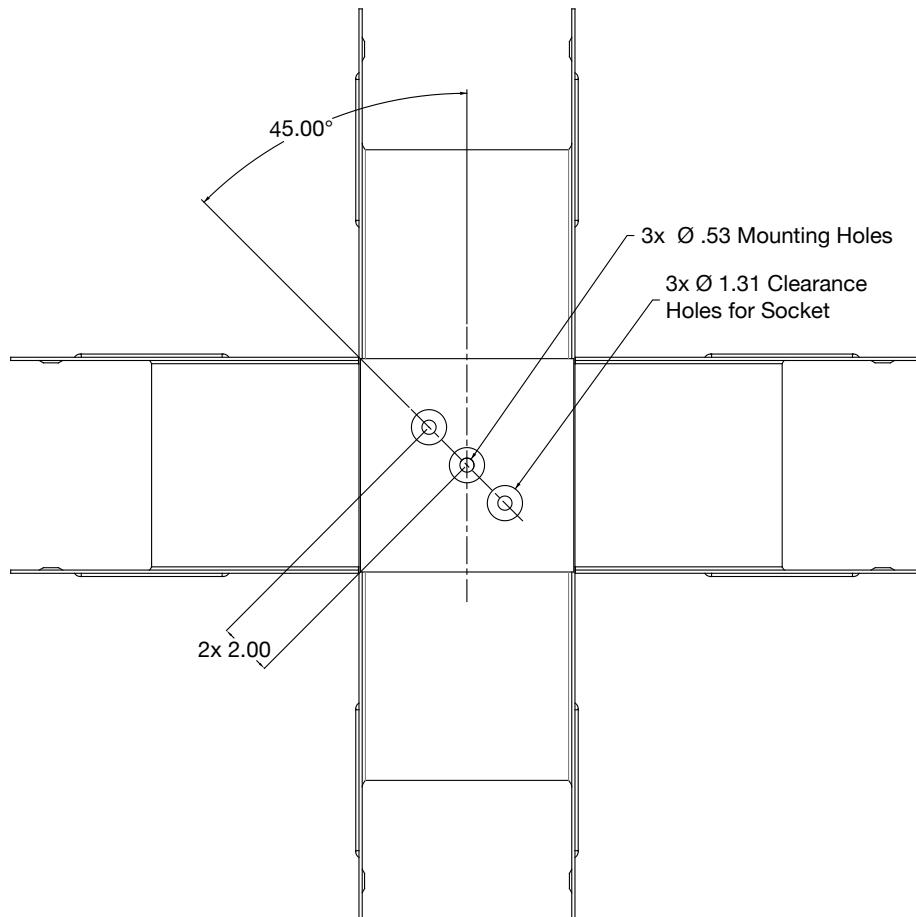

Figure 15 Top view of DSAMK4 bolt hole pattern



**Wall Mount Applications**

For wall mount installation, materials and securing methods may vary depending on local and national electrical codes. You can wall mount the DSA speaker array either outdoors or indoors. A structural engineer may be needed to determine the required mounting method.

**Figure 16 Wall Mount Configuration**

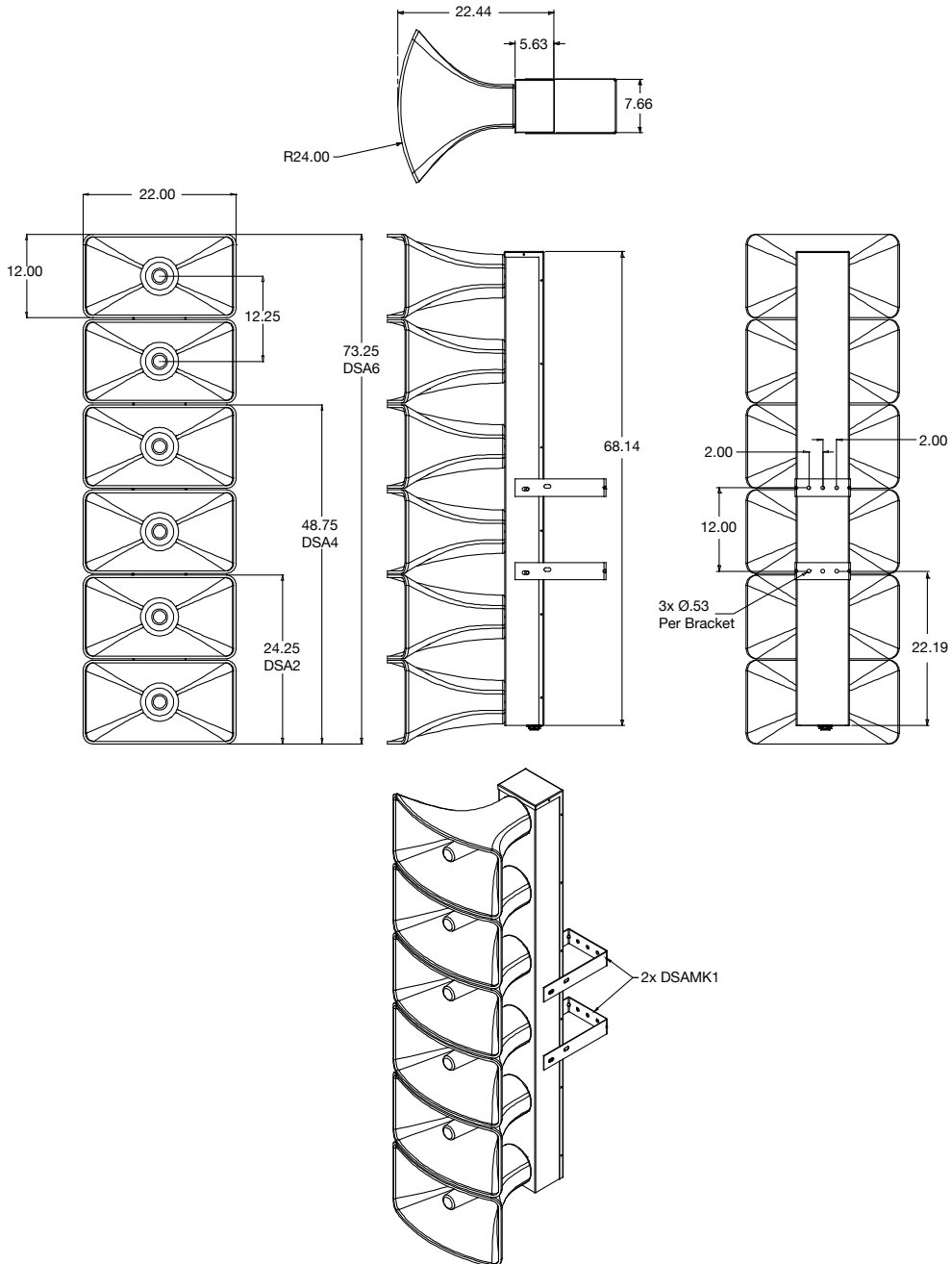

DSA6 Wall Mount Dimensional Configuration

**Figure 17 DSAMKSP Mounting Kit**

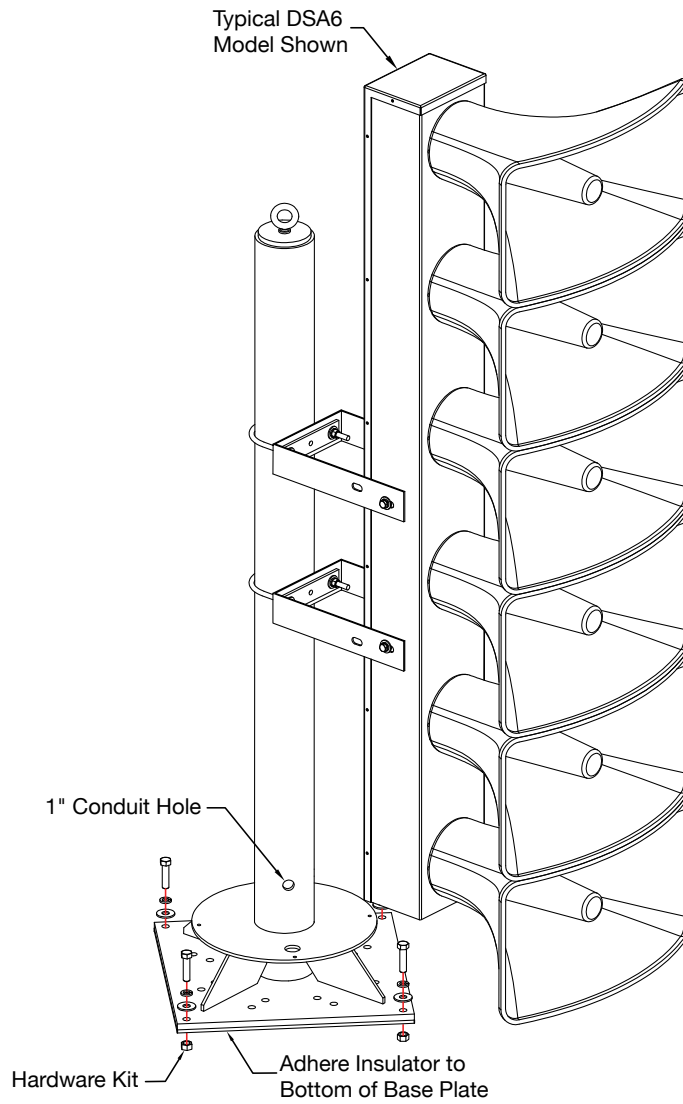

---

## Ordering Parts

To order replacement parts, call Customer Care. See Getting Service.

**Table 8 Replacement Parts**

Description	Part Number
Driver, 100 W	K8570063A

## Getting Service

If you are experiencing any difficulties, contact Federal Signal Customer Care at 800-548-7229 or 708-534-3400 extension 7511 or Technical Support at 800-524-3021 or 708-534-3400 extension 7329 or through e-mail at [techsupport@fedsig.com](mailto:techsupport@fedsig.com). For instruction manuals and information on related products, visit <http://www.fedsig.com>.



# Appendix A DSA Drawings

## Figure 18 DSA Assembly Drawing

ITEM	REQ'D	PART NO.	DESCRIPTION	MODEL USED ON
1	1	8577016A	BACK, COVER	DSA2
		8577012A	BACK, COVER	DSA3 & DSA4
		8577007A	BACK, COVER	DSA5 & DSA6
2	1	8577017A	ENCLOSURE ASSEMBLY	DSA2
		8577009A-01	ENCLOSURE ASSEMBLY	DSA3, DSA4
3	6	7011A136-08	SCR, HX. HD., #6	DSA5 & DSA6
				DSA2
4	1	8570063A	DRIVER, FWS 100W NEO	DSA2
				DSA3
				DSA4
				DSA5
				DSA6
				DSA2
5	17	7000A345-16	SCR, 1/4-20, S.S.	DSA3 & DSA4
				DSA5 & DSA6
6	21	7072A024	WASH, FLT, S.S.	DSA2
				DSA3 & DSA4
7	24	7074A067	LKWASH, SPLT, S.S.	DSA5 & DSA6
				DSA2
8	1	132B133A	PROJECTOR, ATLAS	DSA3 & DSA4
				DSA5 & DSA6
				DSA2
				DSA3
				DSA4
				DSA5
9	1	175791C	CABLE, ASSY., SPKR	DSA2, DSA3, DSA4, DSA5 & DSA6
				DSA2, DSA3, DSA4, DSA5 & DSA6
10	4	7065053A	RIVNUT, 3/8-16, ALUM	DSA2, DSA3, DSA4, DSA5 & DSA6
				DSA2, DSA3, DSA4, DSA5 & DSA6
11	4	7002A009-20	SCR, HX. HD., 3/8-16	DSA2, DSA3, DSA4, DSA5 & DSA6
				DSA2, DSA3, DSA4, DSA5 & DSA6
12	4	7074A046	LKWASH, SPLT, S.S.	DSA2, DSA3, DSA4, DSA5 & DSA6
				DSA2, DSA3, DSA4, DSA5 & DSA6
13	1	8577003A	BRKT, SRN. ADJUST	DSA2, DSA3, DSA4, DSA5 & DSA6
				DSA2, DSA3, DSA4, DSA5 & DSA6
14	0.1oz	R81-11-01	NYOGEL	DSA2, DSA3, DSA4, DSA5 & DSA6
				DSA2, DSA3, DSA4, DSA5 & DSA6
16	2	7072A035	WASH, FLT, 0.38	DSA2, DSA3, DSA4, DSA5 & DSA6
				DSA2, DSA3, DSA4, DSA5 & DSA6
17	1	8577013A	PLATE, COVER	DSA3 & DSA5
				DSA3 & DSA5
18	4	7059A020	NUT, 1/4-20, S.S.	DSA2 & DSA3
				DSA2 & DSA3
19	2	T300218-09-097	WIRE, TERM, 18GA, WHT, 24"	DSA4 & DSA5
				DSA6
20	2	139413A	CONN, PUSH WIRE	DSA2, DSA3, DSA4, DSA5 & DSA6
				DSA2, DSA3, DSA4, DSA5 & DSA6
21	1	8291B012	BAG, POLY, RL, 3X5	DSA2, DSA3, DSA4, DSA5 & DSA6
				DSA2, DSA3, DSA4, DSA5 & DSA6
22	2	161A507A	LABEL, WARNING	DSA2, DSA3, DSA4, DSA5 & DSA6
				DSA2, DSA3, DSA4, DSA5 & DSA6
23	1	81462120A-01	LABEL, MODEL/SERIAL NO.	DSA2
				DSA3
				DSA4
				DSA5
				DSA6
24	1	140514A	MYERS HUB, 1" ALUM.	DSA2, DSA3, DSA4, DSA5 & DSA6
				DSA2, DSA3, DSA4, DSA5 & DSA6
25	1	150190A	CLAMP CABLE	DSA2, DSA3, DSA4, DSA5 & DSA6
				DSA2, DSA3, DSA4, DSA5 & DSA6
26	2	161693A	LABEL, FS LOGO	DSA2, DSA3, DSA4, DSA5 & DSA6
				DSA2, DSA3, DSA4, DSA5 & DSA6
27	1	81461665A	NAMEPLATE	DSA2
				DSA3
				DSA4
				DSA5
				DSA6
				DSA2
28	1	7011A15A-10	SCREW THD FRM PAN HD PHIL TYPE A #6 S.S.	DSA2
				DSA3
				DSA4
				DSA5
				DSA6
				DSA2
29	1	7058050A	NUT LOCK 1/4-20 S.S.	DSA2, DSA3, DSA4, DSA5 & DSA6
				DSA2
				DSA3
				DSA4
				DSA5
30	1	71400720A	LABEL, UL, DSA2	DSA2
				DSA3
				DSA4
				DSA5
				DSA6

\* NOT SHOWN, USED IN SHIPPING

ADHERE LABEL TO BOTH SIDES

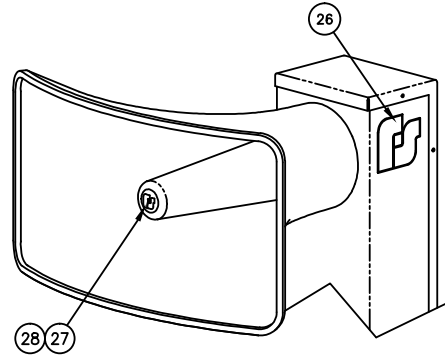

- NOTES: 1. WRAP ANY UNUSED DRIVER LEADS WITH ELECTRICAL TAPE.  
 2. APPLY SMALL AMOUNT OF NYOGEL TO DRIVER TERMINALS.  
 3. TIE BACK UNUSED SPEAKER WIRES AND ISOLATE SO THEY DO NOT SHORT WITH OTHER COMPONENTS.

### DRIVER WIRING

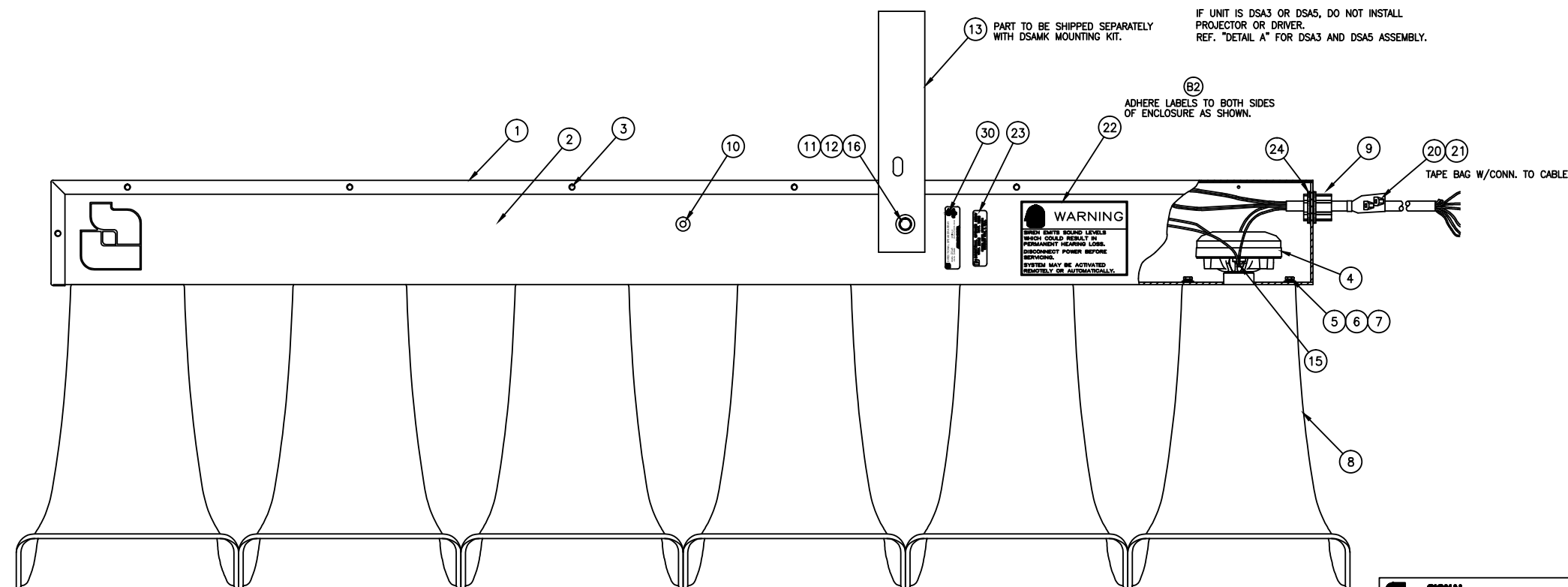
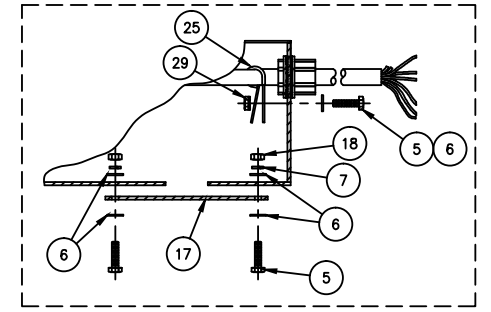
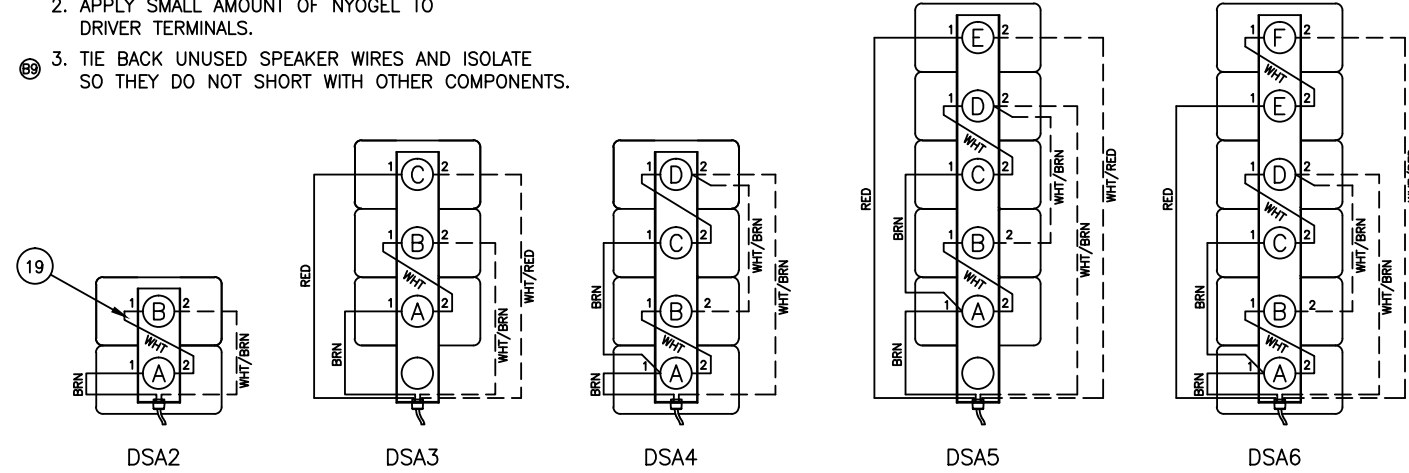

NOTE: TYPICAL DSA6 ASSEMBLY SHOWN.

B9	SEE ECR #6905	3/26/17	MAF	FINISH	N/A
B8	SEE ECR #5373	7/26/16	MAF		
B7	SEE ECO# 08-4020	2/4/08	VT		
B6	SEE ECO# 07-4080	6/4/07	VT	REMOVE BURRS, SHARP CORNERS AND EDGES	
B5	SEE ECO #07-4003	1/2/07	VT	MATERIAL	
B4	SEE ECO #05-4134	8/23/05	MAF	AS NOTED	
B3	SEE ECO# 05-4100	6/2/05	VT		
B2	SEE ECO #03-4095	06/18/03	DAG		
REV.	CHANGE	DATE	BY	FINAL ASSY, DSA SERIES	8577034B

**SIGNAL DIVISION**  
 Federal Signal Corporation  
 2845 FEDERAL SIGNAL DRIVE - UNIVERSITY PARK, IL 60488

MATERIAL DESCRIBED AND INFORMATION CONTAINED IS PROPRIETARY TO FEDERAL SIGNAL CORPORATION, OR MAY BE THE SUBJECT OF PATENT APPLICATIONS, AND MAY NOT BE COPIED, QUOTED TO OTHERS, OR USED FOR MANUFACTURING WITHOUT CONSENT.

SCALE: 10" = 1'-0"  
 DRAWN BY MLL CHD. BY MJF  
 DATE 8/19/98 DATE 8/19/98  
 DRAWING NUMBER

Figure 19 Wiring Options

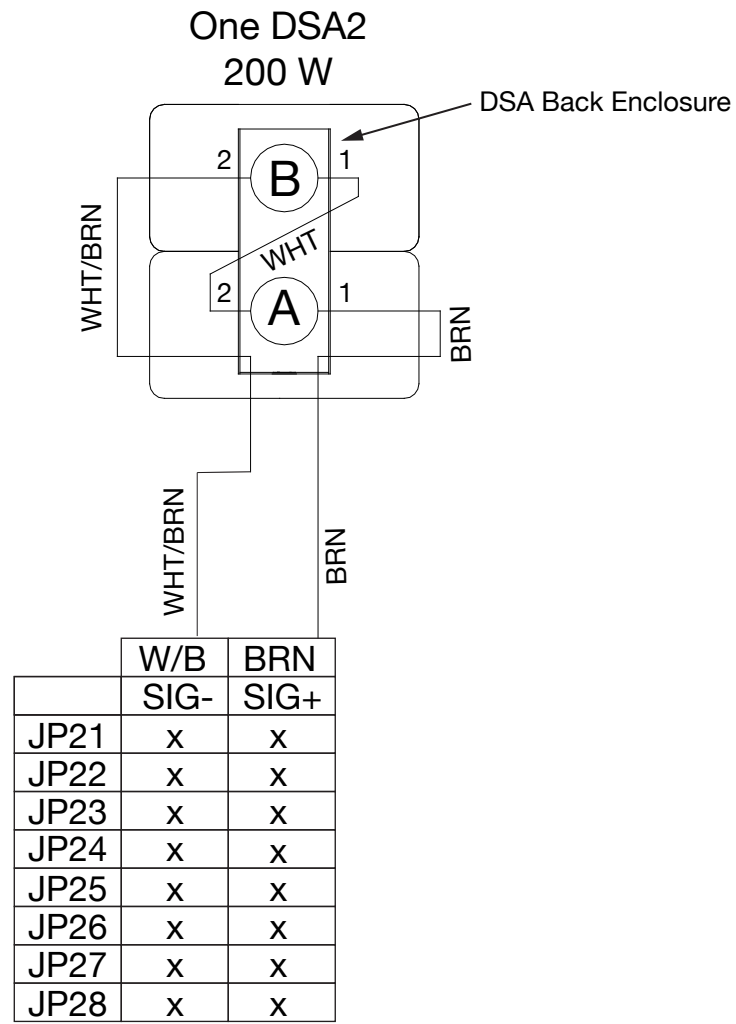

x = Possible connection

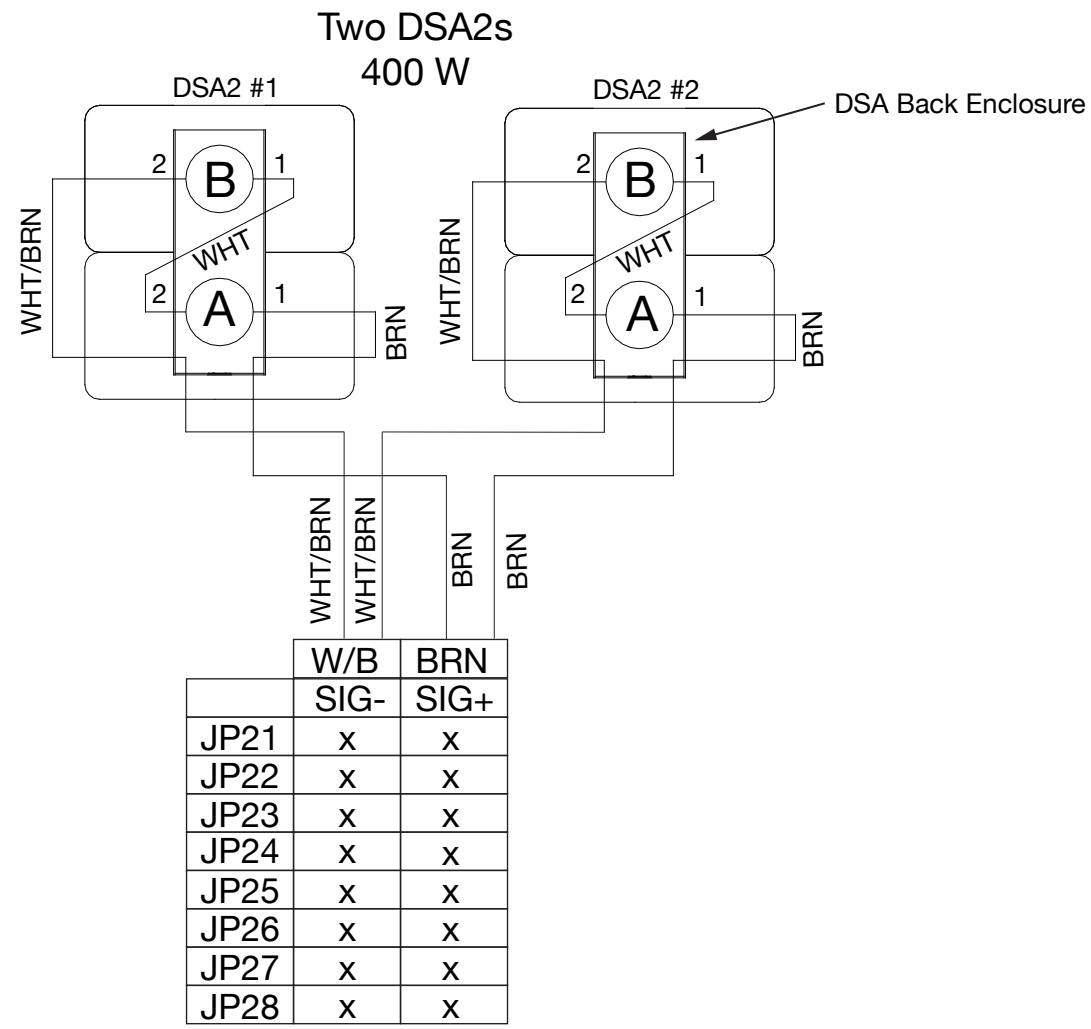

x = Possible connection

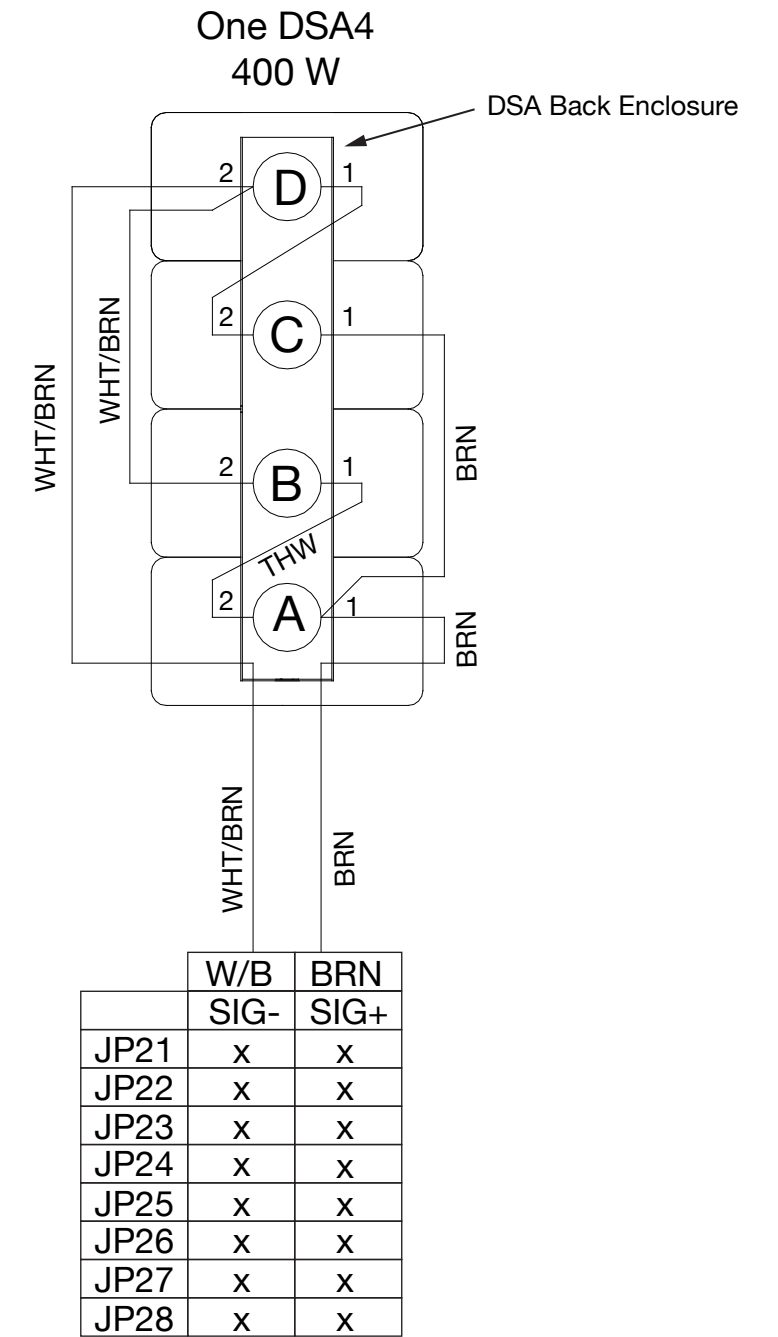

x = Possible connection

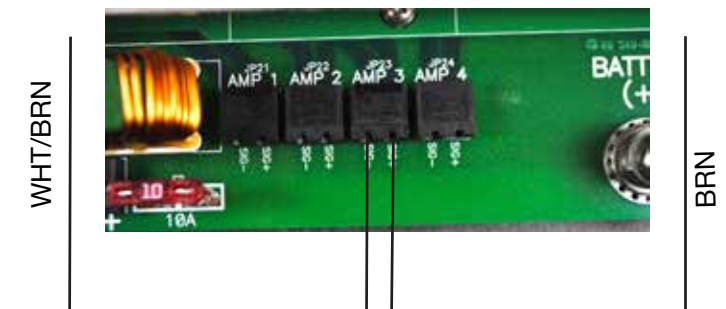
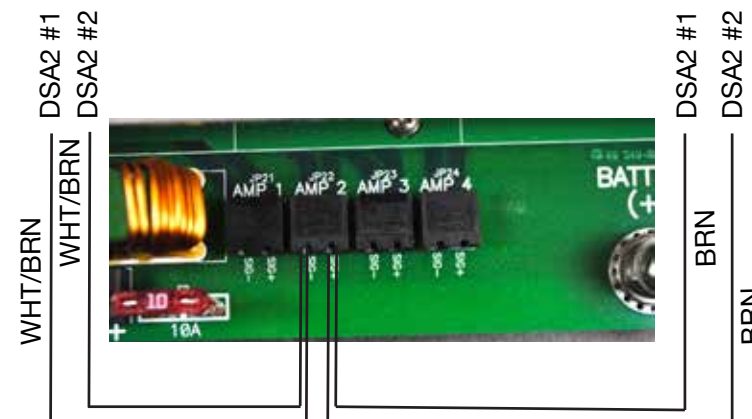
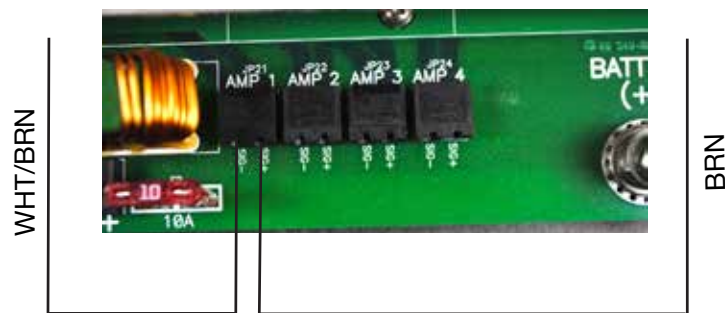
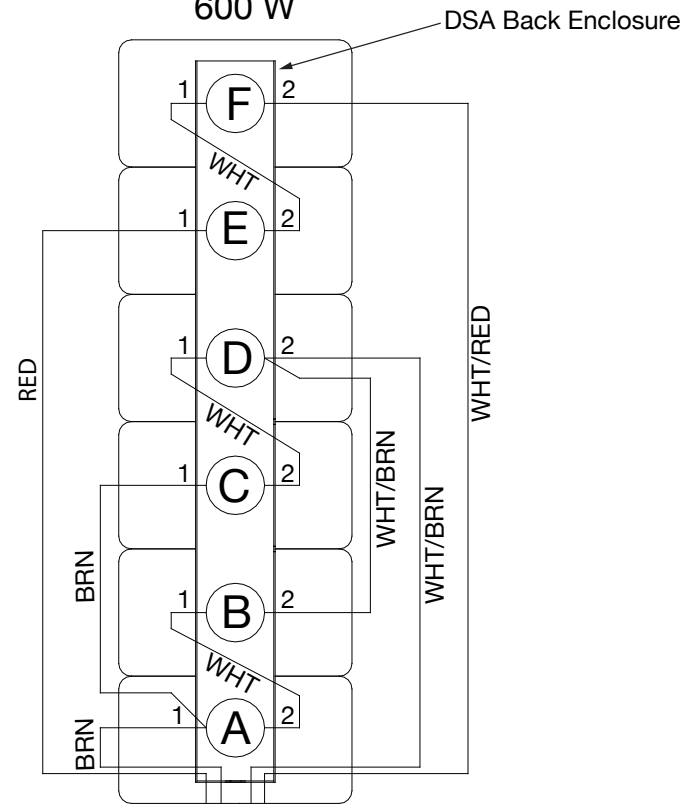

Figure 20 Wiring Options Continued

One DSA6  
600 W



	W/B SIG-	BRN SIG+	W/R SIG-	Red SIG+
JP21	x	x		
JP22			x	x
JP23	x	x		
JP24			x	x
JP25	x	x		
JP26			x	x
JP27	x	x		
JP28			x	x

x = Possible connection

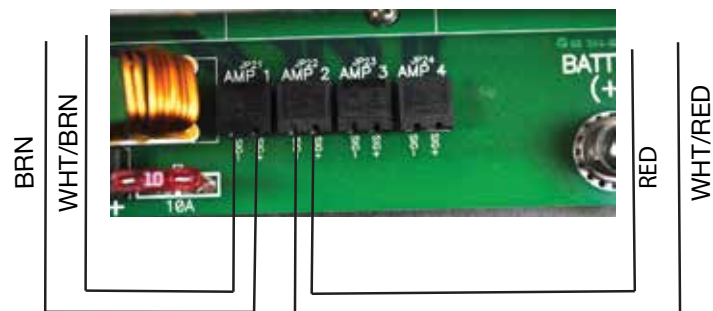

Two DSA6s  
1200 W

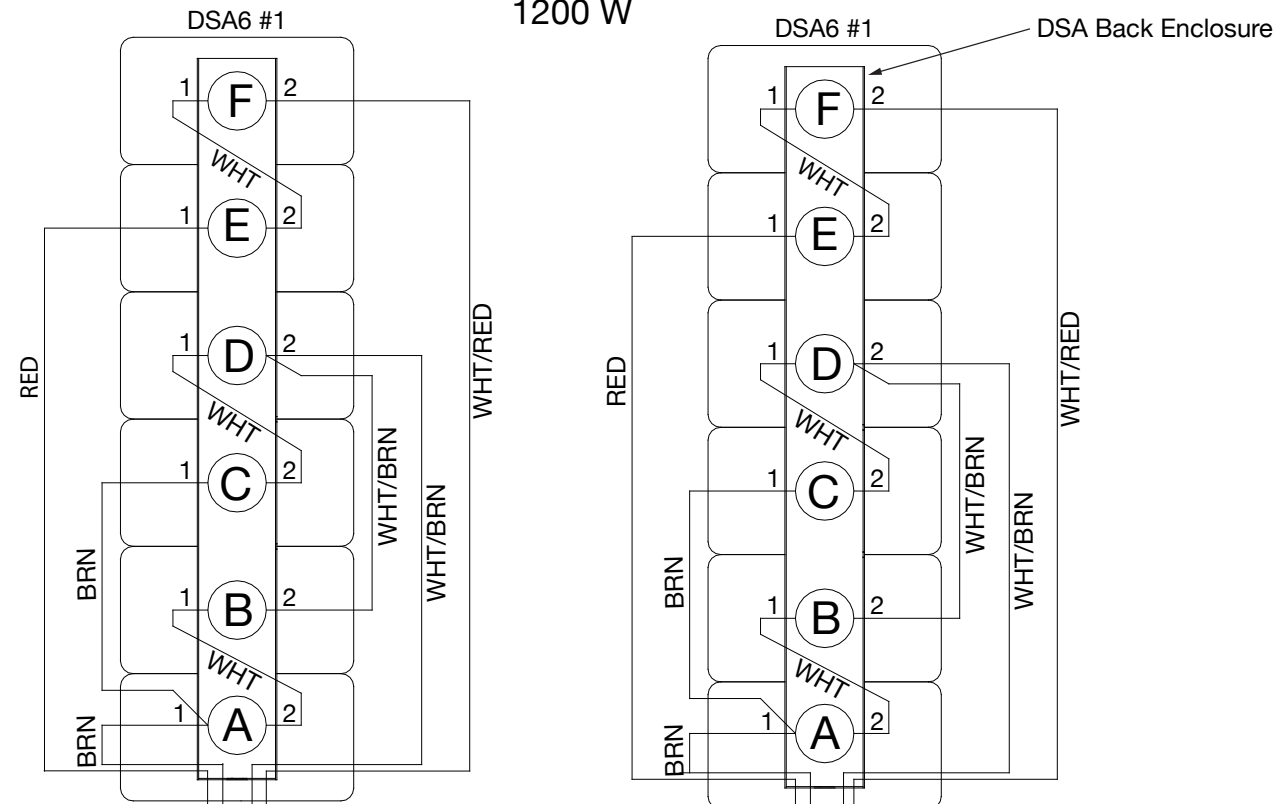

	W/B SIG-	BRN SIG+	W/R SIG-	Red SIG+	W/B SIG-	BRN SIG+
JP21	x	x				
JP22			x	x		
JP23					x	x
JP24	x	x				
JP25			x	x		
JP26					x	x
JP27						
JP28						

x = Possible connection

