

# Informer Sensor Interface Unit

Model I-IPSIU Series C



---

## *Description, Specifications, Installation, and Operation Manual*

## Limited Warranty

This product is subject to and covered by a limited warranty, a copy of which can be found at [www.fedsig.com/SSG-Warranty](http://www.fedsig.com/SSG-Warranty). A copy of this limited warranty can also be obtained by written request to Federal Signal Corporation, 2645 Federal Signal Drive, University Park, IL 60484, email to [info@fedsig.com](mailto:info@fedsig.com) or call +1 708-534-3400.

This limited warranty is in lieu of all other warranties, express or implied, contractual or statutory, including, but not limited to the warranty of merchantability, warranty of fitness for a particular purpose and any warranty against failure of its essential purpose.



**FEDERAL SIGNAL**  
Safety and Security Systems

2645 Federal Signal Drive  
University Park, Illinois 60484

[www.fedsig.com](http://www.fedsig.com)

Customer Support      800-548-7229 • +1 708 534-3400

Technical Support      800-524-3021 • +1 708 534-3400

All product names or trademarks are properties of their respective owners.

---

## Contents

<b>Safety Messages</b> .....	<b>5</b>
Safety Messages to Installers .....	5
<b>General Description</b> .....	<b>8</b>
Introduction .....	8
Features.....	8
Package Contents.....	9
Ordering Information .....	9
Radio Cables .....	10
<b>Specifications</b> .....	<b>11</b>
<b>Installation</b> .....	<b>12</b>
Determine a Suitable Location .....	12
Rack Mounting .....	13
Wall Mounting .....	14
Electrical Connections .....	15
<b>Operations</b> .....	<b>16</b>
Input/Output Locations .....	16
Visual Indications .....	16
Ethernet Port (PoE).....	16
Power Input.....	16
Serial Port .....	16
Carrier Detect/Rear Input.....	16
Digital Inputs .....	17
Relay Outputs .....	17
Audio Input.....	17
Radio and Audio PTT Outputs .....	17
Memory Card Removal and Installation.....	18
<b>Testing and Training</b> .....	<b>18</b>
<b>Replacement Parts</b> .....	<b>19</b>
<b>Getting Service</b> .....	<b>19</b>

---

## Tables

Table 1 Package Contents .....	9
Table 2 Ordering Information .....	9
Table 3 Optional Accessories .....	9
Table 4 Universal Adapter Cable Part Numbers .....	10
Table 5 Radio Interface Cables Part Numbers .....	10
Table 6 Specifications .....	11
Table 7 Visual Indications .....	16
Table 8 Carrier Detect/Rear Input .....	16
Table 9 Audio Input .....	17
Table 10 JP3 Radio and Audio PTT Outputs .....	18
Table 11 Replacement Connectors Part Numbers .....	19

## Figures

Figure 1 Attach Bracket .....	13
Figure 2 Rack Mount Dimensions .....	13
Figure 3 Attach Bracket .....	14
Figure 4 Wall Mount Dimensions .....	14
Figure 5 Radio Cable Wiring Drawing .....	15
Figure 6 I-IPSIU Input/Output Locations .....	16

---

## Safety Messages

**⚠ WARNING**

It is important to follow all instructions shipped with this product. This device is to be installed by trained personnel who are thoroughly familiar with the country's electric codes and will follow these guidelines as well as local codes and ordinances, including any state or local noise-control ordinances. Listed below are important safety instructions and precautions you should follow:

**Important Notice**

Federal Signal reserves the right to make changes to devices and specifications detailed in the manual at any time in order to improve reliability, function, or design. The information in this manual has been carefully checked and is believed to be accurate; however, no responsibility is assumed for any inaccuracies.

**Planning**

- If suitable warning equipment is not selected, the installation site for the Informer is not selected properly or the Informer is not installed properly, it may not produce the intended optimum audible warning. If applicable, follow Federal Emergency Management Agency (FEMA) recommendations.
- If the Informer is not activated in a timely manner when an emergency condition exists, it cannot provide the intended audible warning. It is imperative that knowledgeable people, who are provided with the necessary information, be available at all times to authorize activation.
- The sound output of the Informer is capable of causing permanent hearing damage. To prevent excessive exposure, carefully plan placement, post warnings, and restrict access to areas near sirens. Review and comply with any local or state noise control ordinances as well as OSHA noise exposure standards, regulations, and guidelines.
- Activating the Informer may not result in people taking the desired actions if those to be warned are not properly trained about the meaning of warning sounds. Users should follow FEMA recommendations and instruct those to be warned of correct actions to be taken.

After installation, service, or maintenance, test the system to confirm that it is operating properly. Test the system regularly to confirm that it will be operational in an emergency.

## Safety Messages to Installers

People's lives depend on your safe installation of our products. It is important to follow all instructions shipped with this product. This device is to be installed by a trained electrician who is thoroughly familiar with the National Electrical Code and/or Canadian Electrical Code and will follow the NEC and/or CEC Guidelines as well as all local codes.

The selection of the mounting location for this Informer, its controls, and the routing of the wiring is to be accomplished under the Facilities Engineer and the Safety Engineer's direction. Listed below are some other important safety instructions and precautions you should follow:

- Electrocution or severe personal injury can occur when performing various installation and service functions such as making electrical connections, drilling holes, or lifting equipment. Therefore, only experienced electricians should install this

product per national, state, and any other electrical codes having jurisdiction. Perform all work under the direction of the installation or service crew safety foreman.

- Read and understand all instructions before installing, operating, or servicing this equipment.
- All effective warning sounds may, in certain circumstances, cause permanent hearing loss. Take appropriate precautions, such as wearing hearing protection. The maximum sound level exposure limits specified in OSHA 29 CFR 1910 should not be exceeded. Review and comply with any local or state noise control ordinances as well as OSHA noise exposure regulations and guidelines.
- For optimum sound distribution, do not install this speaker where objects would block any portion of the front of the Informer.
- Establish a procedure to check the signal system for proper activation and operation routinely.
- Any maintenance to the unit **MUST** be performed by a trained electrician per NEC Guidelines and local codes or a Federal Signal certified Service Provider.
- Never alter the unit in any manner.
- The nameplate should **NOT** be obscured, as it contains cautionary and/or other information of importance to maintenance personnel.
- After installation and completion of the initial system test, provide a copy of these instructions to all personnel responsible for the operation, periodic testing, and equipment maintenance.
- File these instructions safely and refer to them when maintaining and/or reinstalling the device.

Failure to follow all safety precautions and instructions may result in property damage, serious injury, or death.

### **Installation and Service**

- After installation or service, test the system to confirm that it is operating properly. Test the system regularly to confirm that it will be operational in an emergency.
- If future service and operating personnel do not have these instructions to refer to, the system may not provide the intended audible warning, and service personnel may be exposed to death, permanent hearing loss, or other bodily injuries. File these instructions in a safe place and refer to them periodically. Give a copy of these instructions to recruits and trainees. Also give a copy to anyone who is going to service or repair the Informer.
- To reduce the risk of electric shock, do not perform any servicing other than what is contained in the operating instructions unless you are qualified to do so. Refer all servicing to qualified service personnel. Always test the Informer before using after repairs have been made.

### **Ethernet Wiring**

- Unless shielded or run in conduit, Ethernet wiring must be at least six feet from bare power wiring or lightning rods and associated wires, and at least six inches from other wire (for example, antenna wires, doorbell wires, wires from transformers to neon signs), steam or hot water pipes, and heating ducts.

- Do not place Ethernet wiring or connections in any conduit, outlet or junction box containing high voltage electrical wiring.

**Symbol Definition**

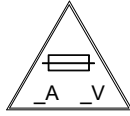

Indicates to reduce the risk of fire, replace the fuse as marked.

**Hazard Classification**

Federal Signal uses signal words to identify the following:

**▲ DANGER**

DANGER indicates a hazardous situation which, if not avoided, will result in death or serious injury.

**▲ WARNING**

WARNING indicates a hazardous situation which, if not avoided, could result in death or serious injury.

**▲ CAUTION**

CAUTION indicates a hazardous situation which, if not avoided, could result in minor or moderate injury.

**NOTICE**

NOTICE is used to address practices not related to physical injury.

Pay careful attention to the notice located on the equipment.

***Read and understand the information contained in this manual before attempting to install or service the Informer.***

## **General Description**

### **Introduction**

The Informer Sensor Interface Unit (I-IPSIU) enhances notification capabilities by connecting to and controlling external devices and third-party equipment. An Informer I-IPSIU automatically initiates predefined alerts by sensing changes in dry contact closure status resulting from a panic button or alarm system activation, PLC equipment failure, motion-sensor detection, pre-designated temperature-sensor settings, etc. Opto-isolated inputs enable each I-IPSIU to sense and monitor 16 different external devices simultaneously. Each input can be programmed to activate a predefined template or action (such as a relay closure) or alert.

I-IPSIUs provide the ability to control and activate up to four devices or equipment through receipt of an alert or template from Federal Signal Commander control and activation software. The four output relays provide normally open and closed contacts, support tasks ranging from turning lights on/off to activating alarm systems, strobe lights, sirens, and door locks.

An I-IPSIU can also interface with a mobile or portable radio to broadcast alert messages over the radio system. The I-IPSIU has carrier detect capability to delay broadcast until the radio system is idle. Broadcasts can be pre-programmed tones, digital voice messages, or live PA broadcasts.

A single alert or activation can activate multiple I-IPSIUs in support of multi-site notifications, thereby making it the ideal solution for large industrial complexes, healthcare facilities, schools, university campuses, and office buildings.

See the Informer-IP Series C Setup, Program, and User Manual (part number 25500395 revision C or later) to learn how to set up, configure, program, and use Informer-IP devices.

### **Features**

The I-IPSIU has the following features; some features require using the Federal Signal Commander® software system:

- Add external I/O interfaces to a Federal Signal Intelligent system or alerting and notification system.
- Sixteen closure points sense status changes in panic buttons, PLCs, equipment, remote sensors and local alarm systems to initiate predefined alerts.
- Removable microSD card for custom message generation. Store up to 4000 voice or tone messages that total up to 17 hours of recording time.
- Integrated Modbus® TCP industrial PLC interface for control and monitoring.
- Integrated SIP phone interface for live PA, remote wave file, and function control.
- Commander and CommanderOne® HMI software provide configuration, control, activation, and notification options.
- Four output relays to control access controls systems, locks, lights, flashers, speakers, sirens, evacuation systems, etc.
- Radio interface for digital voice messages-to-radio communications.



- 19-inch rack, wall, or desk mounting options.
- Compact size (1 RU) supports easy deployment.
- 8-30 Vdc operating voltage range or PoE powered.
- Removable connectors with built-in strain relief for external connections.
- Supports fixed IP, DHCP, and Auto-IP.
- Wired Ethernet.
- Seven factory-installed siren tones: wail, alternate wail, pulsed wail, steady, alternate steady, pulsed steady, and Westminster chime (auxiliary).
- LED status indicator for Power.
- Informers are addressable Individually, in Groups, or All.
- Requires minimal network bandwidth and uses TCP/IP protocol for security and reliability.
- Remote supervision of Communications, Audio Output, Alert Function Execution.
- Works with redundant Commander network servers for reliable fail-safe operation with full two-way control, status monitoring and configuration of the I-IPSIU.

## Package Contents

**Table 1 Package Contents**

Description	Part Number	Qty
I-IPSIU Chassis	864600301A	1
Foam Inserts	78000806A	2
Instruction Sheet	25500527	1
Power Supply	120272A	1
Cable Ties	150A146A	2

## Ordering Information

**Table 2 Ordering Information**

Part Numbers	Description
I-IPSIU	I-IPSIU Sensor Interface Unit (Includes 19-inch rack mount and wall mounting)

You can order the following accessories separately.

**Table 3 Optional Accessories**

Part Numbers	Description
I-SMD2-36	Scrolling Message Display (2 x 36 inches)
I-IP-SW	Informer-IP Setup Wizard Software and Cable
PSEV-YM	Yellow Station with Momentary Contact – “EVACUATION”
PSEVSC-YM	Yellow Station with Momentary Contact and Sounder Cover – “EVACUATION”
PSEM-RM	Red Station with Momentary Contact – “EMERGENCY”

## General Description

Part Numbers	Description
PSEMSC-RM	Red Station with Momentary Contact and Sounder Cover – “EMERGENCY”

## Radio Cables

Use Tables 8, 9, and 10 in the Operations section to interface to the radio system or other external broadcast systems. Use Tables 4 and 5 to interface between the I-IPSIU and radio. The Universal Adapter Cable provides flying leads on one end and a DB9 connector on the other. The DB9 connector interfaces to a second cable, which provides the interface to the radio.

Determine if the radio provides a contact closure for carrier detect or audio. If contact closure is provided, use the C.D./Rear Input for Carrier Detect. If audio is provided, use the Audio input for Carrier Detect. Audio from the I-IPSIU to the radio uses JP3 pins 1 and 2. PTT from the I-IPSIU to the radio uses JP3 pins 3 and 4.

The Universal Cable Adapter is provided with each I-IPSIU. Find the proper cable for your radio system and order separately.

**Table 4 Universal Adapter Cable Part Numbers**

Description	Part Number
NX-5000 cable to the I-IPSIU and radio	17501602B
I-IPSIU Universal Adapter Cable	17501574A

**NOTE:** The Kenwood NX-5000 cable goes directly to the I-IPSIU without the need for an I-IPSIU Universal Adapter Cable (model number 17501574A). The I-IPSIU Universal Adapter Cable is still required for all other radio models in addition to the radio specific cable for the other radio models.

The following table lists the available radio interface cable options. One per radio is required.

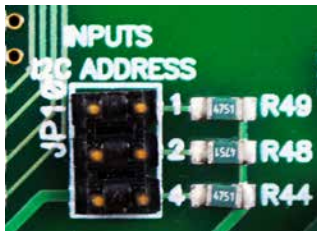

**Table 5 Radio Interface Cables Part Numbers**

Description	Part Number
Motorola XTN/CP200/BPR40	864700073A
Motorola HT 1000, XTS 5000	864700074A
Kenwood (TK2170,TK2302V, NX-240V,NX-340U)	864700075A
BENDIX KING	864700076A
Motorola HT 1250 & Compatible	864700077A
Icom F11S	864700078A
Motorola CDM 750/1550/CM200/CM300 LS/PM400	864700080A
Motorola Turbo XPR6550, APX7000 & Compatible	864700081A
Motorola XPR 4550, ALL XPR Mobile	864700082A
Motorola MCS 2000 DB25 Rear Connector	864700083A
M/ACOM M7100	864700084A
M/ACOM M7300	864700085A
Kenwood TK-480,TK-5320	864700086A
MACOM P7100 SERIES, MC-1527 PRYME	864700087A

Description	Part Number
Kenwood TK5810	864700103A
Kenwood TK790	864700104A
Motorola Astro XTL 1500, 2500, 5000, APX7500	864700105A
Hirose Plate Assy with male female extension	864700136A

## Specifications

**Table 6 Specifications**

Operating Voltages	9-15 Vdc 108-128 Vac, 60 Hz with wall transformer
Operating Current	Standby (at 12 Vdc) < 200 mA Signaling (at 12 Vdc) < 500 mA
Operating with PoE, IEEE 802.3af, 48V input	PoE: 48 Vdc (42 to 57 Vdc), IEEE 802.3af Standby (at 48 Vdc) < 50 mA Signaling (at 48 Vdc) < 160 mA
Audio Data	8000 samples/sec, $\mu$ Law compression
Audio Data Playback Storage	17 hours and 4,000 messages with 2 GB microSD card
Audio Frequency response	300-3000 Hz, +1 to -3 dB per octave
Warning Siren Audio	Seven factory-installed siren tones: wail, alternate wail, pulsed wail, steady, alternate steady, pulsed steady, and Westminster chime (auxiliary)
Serial Port	RS232C, N, 8, 1 Baud rate configurable
Ethernet Port	IEEE 802.3, 10/100 BASE-T connection
Port Address	16887
Digital Inputs (JP10 Input I2C Address on the I/O board should be set to zero.) No jumpers are installed.	16 surge protected, optically-isolated inputs accept dry contact closure or open-collector outputs with < 5 kilohms impedance. Connectors accept 16-24 AWG wire.
	
Relay Outputs (JP11 Relay I2C Address on the I/O board should be set to one.)	Four Relay Outputs with Normally Open and Normally Closed contacts. Each contact rated at 5 A at 30 Vdc Connectors accept 14-22 AWG
	
Operating temp range	-22°F to +140°F (-30°C to +60°C)

Humidity range	0-95%, non-condensing
Size (H x W x L)	1.7 x 14.0 x 6.4 inches (43.5 x 355.6 x 163.6 mm)
Weight	2.5 lb (1.1 kg)
Shipping Weight	4 lb (1.8 kg)
Electrical Code Compliance	Complies with UL 60065 and CAN/CSA Std. C22.2 No. 60065

## Installation

### **⚠ WARNING**

***Read and adhere to all safety warnings in this manual before installing the I-IPSIU.***

***To prevent injury, this apparatus must be securely attached to the wall per the installation instructions.***

### **⚠ DANGER**

***ELECTROCUTION HAZARD: Electrocution or severe personal injury can occur when making electrical connections, drilling holes, or lifting equipment. Therefore, experienced electricians per national and local electrical codes, acting under the direction of the installation crew safety foreman, should perform installation.***

## Determine a Suitable Location

When choosing a location for the I-IPSIU, consider the following criteria:

- Place as far as possible from electrically noisy electronic devices to avoid interference. Examples of noisy devices may include microwave ovens, motor-driven devices, light ballasts, and electrical switching devices.
- Requires a connection to a wired or wireless Ethernet network, depending on the model purchased. Ethernet wire runs must be less than 328 feet (100 meters) from the nearest network switch.
- Rack or wall mounting is recommended after you have found a suitable location.
- Place within 6 feet (1.8 meters) of an AC power receptacle to eliminate the need for an extension cord unless a Power over Ethernet (PoE) connection is available.

## Rack Mounting

The I-PSIU is designed for a 19-inch rack mount. Attach the bracket to the I-PSIU with supplied screws.

**Figure 1 Attach Bracket**

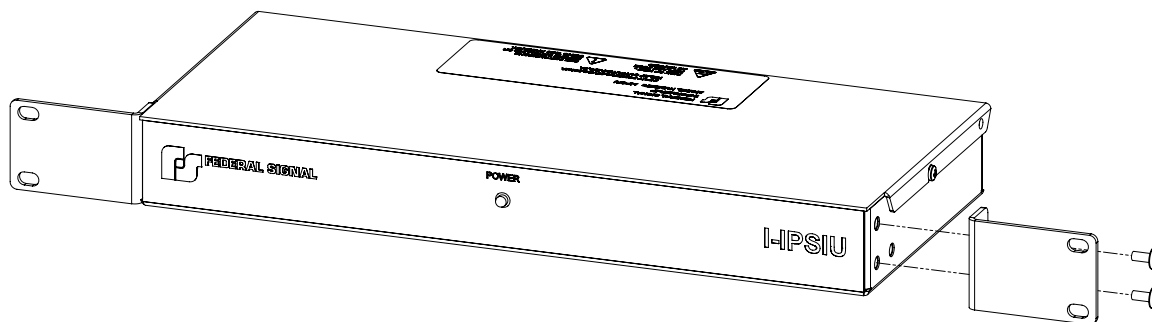

**Figure 2 Rack Mount Dimensions**

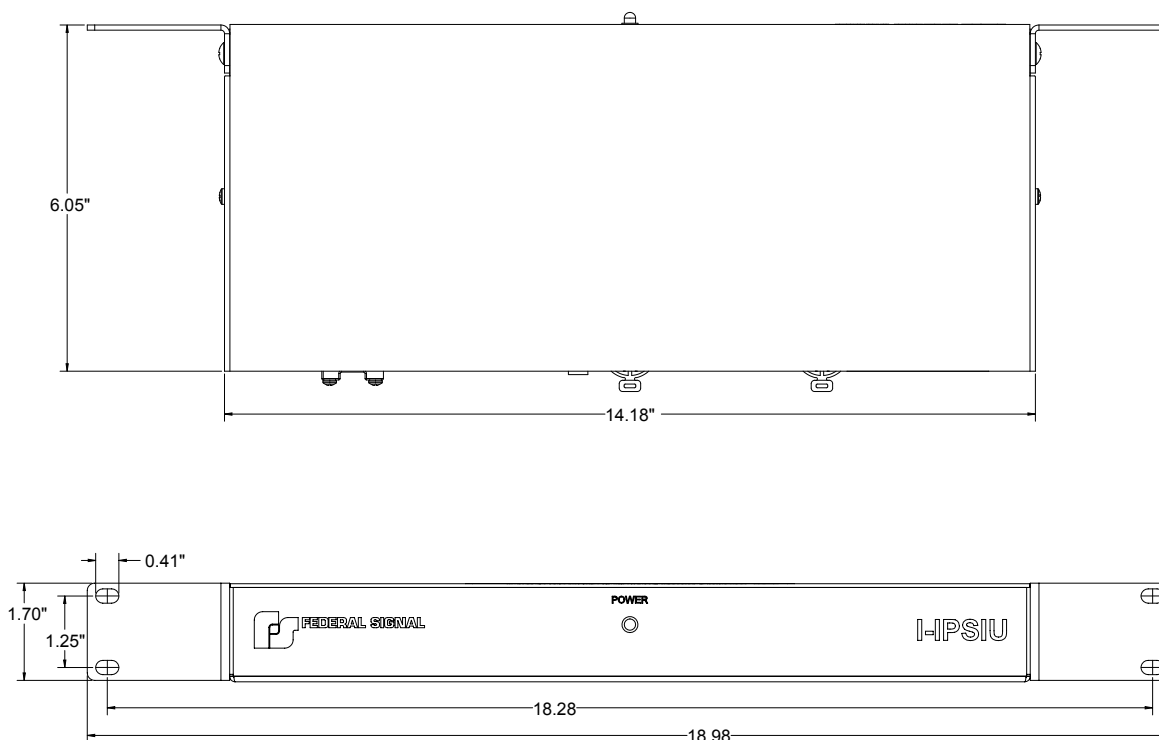

Connect each I-PSIU to the LAN using CAT5 cable. If the Wired Ethernet has PoE, no other power connection is required.

If PoE is not available, run the supplied AC/DC power supply against the wall and plug it into a 120 Vac, 60 Hz outlet. Plug the low voltage end of the cord into the power jack located at the rear of the I-PSIU. Route the cord to ensure it is protected against walking on, tripping over, or pinching the cord.

## Wall Mounting

The I-PSIU can also be wall mounted by moving the mounting brackets. Before mounting the unit, determine a suitable location considering the criteria listed. Ensure the screws are placed into material that can adequately support the weight of the I-PSIU. The maximum bolt diameter that fits the bracket slot when mounting to drywall is #12. Ensure that the screws are tightened sufficiently to fasten the I-PSIU against the wall securely.

**Figure 3 Attach Bracket**

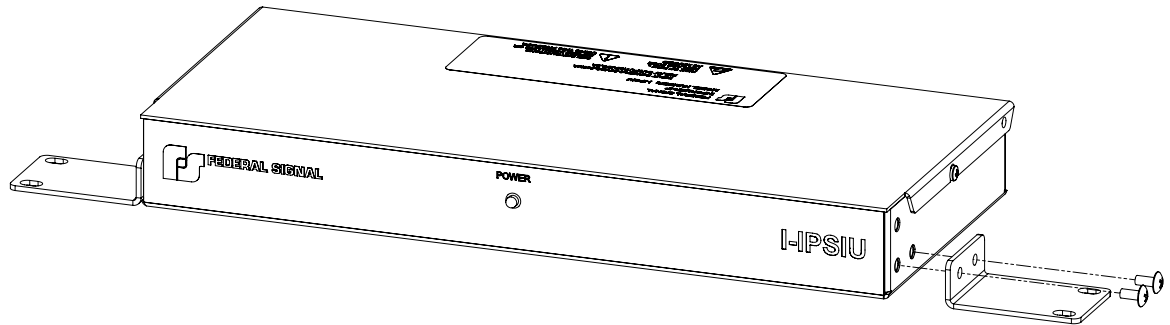

Connect the I-PSIU to the LAN using CAT5 cable. If the Wired Ethernet has PoE, no other power connection is required.

If PoE is not available, run the supplied external AC/DC power supply against the wall and plug it into a 120 Vac, 60 Hz outlet. Plug the low-voltage end of the cord into the power jack located at the rear of the I-PSIU. Route the cord to ensure it is protected against walking on, tripping over, or pinching the cord.

**Figure 4 Wall Mount Dimensions**

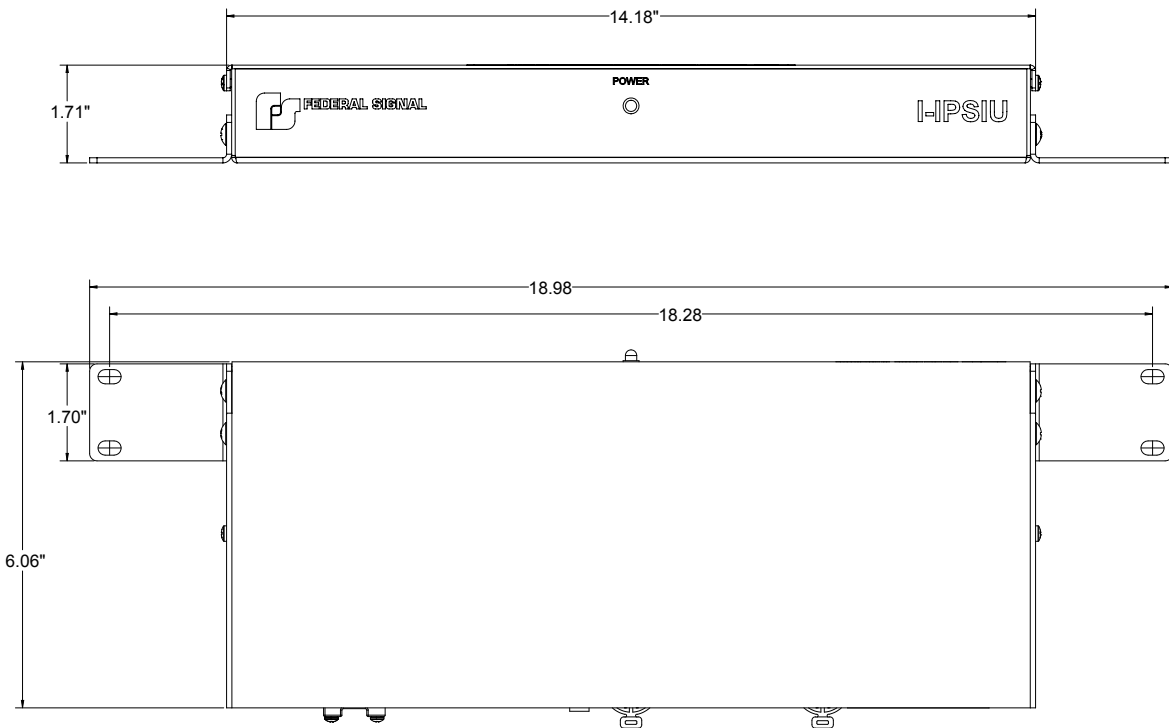



# Operations

## Input/Output Locations

Figure 6 I-IPSIU Input/Output Locations

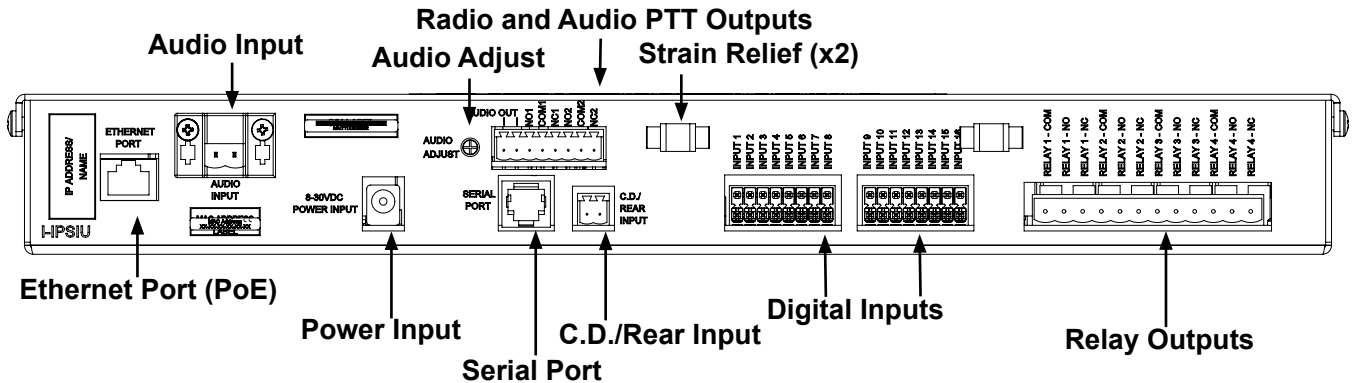

## Visual Indications

Table 7 Visual Indications

LED	Description
POWER	The green Power LED turns on when power is connected and the device is connected to a Federal Signal enabled network server. The Power LED flashes on and off at a 100 ms when the unit is disconnected from the server.

## Ethernet Port (PoE)

The I-IPSIU has an eight-pin Ethernet port for connecting to the communications network. Ethernet wire runs must be less than 328 feet (100 meters) from the nearest network switch. The wired Ethernet port auto-negotiates a 10/100, full or half-duplex connection. Port 16887 must be open for TCP/IP communications for the I-IPSIU to connect to the Commander server.

## Power Input

Route the DC power cord through the strain relief located next to the digital input and plug it into the I-IPSIU. Plug the external AC/DC power supply into a 120 Vac outlet after all other connections have been made. The center connector connects to the positive lead on the DC supply.

## Serial Port

The RS232 port uses a six-pin modular connector. Use the serial port to interface a message board.

## Carrier Detect/Rear Input

The Carrier Detect/Rear Input is used when the radio system provides a contact closure for carrier detect.

Table 8 Carrier Detect/Rear Input

Terminal	Description
1 and 2	Input from radio to indicate when radio is in use.



## Digital Inputs

The digital input connectors accept 16-24 AWG wire. Route the digital input wires through the supplied strain relief near the connector or user-supplied strain relief. Ensure all high-voltage and low-voltage wiring is physically separated or properly insulated. The digital inputs are labeled from 1-16. Connect the top pin to the bottom pin to activate the input. The connection must have a resistance of fewer than 5 kilohms. All the pins on the bottom row of the digital inputs are tied to isolated ground.

## Relay Outputs

### **⚠ WARNING**

**Do not exceed the 10 A, 250 Vac, 30 Vdc resistive load rating specified for the relay. The contacts must be de-rated for the load type used.**

Keep all high-voltage and low-voltage wiring separated. If high-voltage and low-voltage wiring must be run together, all wiring must have an insulation rating greater than the maximum circuit voltage.

The relay output connectors accept 14-22 AWG wire. Four dry relay output contacts are provided with both normally open and normally closed contacts.

## Audio Input

The Audio Input is used to detect channel busy audio. The Audio Input detects from 50 mV to 500 mV<sub>p-p</sub>.

**Table 9 Audio Input**

Terminal	Description
1 and 2	Input from radio to indicate when radio is in use.

## Radio and Audio PTT Outputs

The I-IPSIU has two SPDT relays rated at 5 A at 30 Vdc. The relays are preset to activate when a voice message is initiated. These relays are used to activate the push-to-talk (PTT) on the radio equipment.

**NOTE:** The relay Radio PTT must be programmed to engage during the activation. See the Informer-IP Series C Setup, Program, and User Manual (part number 25500395 revision C or later) to learn how to set up, configure, program, and use Informer-IP devices.

### **Audio Out/Adjust**

The audio output level is adjustable from 0 to 2.5 V<sub>p-p</sub> into 600 ohms with a 1 kHz tone.

A removable eight-position connector is located on the rear of the I-IPSIU for making electrical connections. The connector accepts 3/16-inch (5 mm) stripped wire, 18-26 AWG.

Make electrical connections to the Input/Output connector as follows.

**Table 10 JP3 Radio and Audio PTT Outputs**

JP3 Terminal	(Field Wiring) 1 – Audio Out 2 – Audio Out 3 – Normally open, relay #1 4 – Common, relay #1 5 – Normally closed, relay #1 6 – Normally open, relay #2 7 – Common, relay #2 8 – Normally closed, relay #2
--------------	--

## Memory Card Removal and Installation

The microSD card stores voice and tone messages.

To remove the card:

1. Remove the top of the Informer.
2. Find the microSD card.
3. The PCB may require removal from the enclosure for the microSD card to be removed.
4. Gently push the card into the slot. The card can then be removed.

To install the card:

1. Insert and gently push the card until it latches into place.
2. Replace cover and tighten screws.

## Testing and Training



After the installation is complete:

- Test the I-IPSIU and all accessories from the control point(s) to ensure it is operating properly.
- Ensure all users are properly trained to use the system before putting the I-IPSIU into service.
- Verify all tone, voice, and text messages contain the correct content per the emergency operating plan. Alerts should exceed the ambient sound levels by at least 10 dB to ensure they can be heard.
- Conduct testing regularly per facility safety plans to ensure the equipment remains in working order and operators remain familiar with the use of the equipment.

# Replacement Parts

The I-IPSIU uses one of these two types of connectors: one with slots or one without slots. Match the eight-pin connector of your Informer to the picture below and order the corresponding part number.

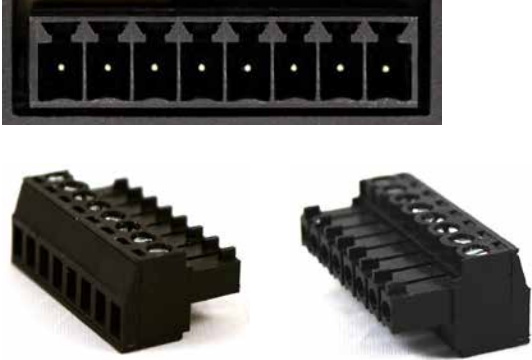
**Table 11 Replacement Connectors Part Numbers**

Picture	Part Number
	13900406A-08
	140372A-08

## Getting Service

If you are experiencing any difficulties, contact Federal Signal Customer Support at 800-548-7229 or 708-534-3400 extension 7511 or Technical Support at 800-524-3021 or 708-534-3400 extension 7329 or e-mail at [techsupport@fedsig.com](mailto:techsupport@fedsig.com). For instruction manuals and information on related products, visit <http://www.fedsig.com>.



**FEDERAL SIGNAL**  
Safety and Security Systems

2645 Federal Signal Drive  
University Park, Illinois 60484

[www.fedsig.com](http://www.fedsig.com)

Customer Support	800-548-7229 • +1 708 534-3400
Technical Support	800-524-3021 • +1 708 534-3400