



Model 2001-AC

220 Vac-to-48 Vdc Transformer with
Contactors and Enclosure

***Description, Specifications, Installation,
Operation, and Service Manual***

Limited Warranty

This product is subject to and covered by a limited warranty, a copy of which can be found at www.fedsig.com/SSG-Warranty. A copy of this limited warranty can also be obtained by written request to Federal Signal Corporation, 2645 Federal Signal Drive, University Park, IL 60484, email to info@fedsig.com or call +1 708-534-3400.

This limited warranty is in lieu of all other warranties, express or implied, contractual or statutory, including, but not limited to the warranty of merchantability, warranty of fitness for a particular purpose and any warranty against failure of its essential purpose.



FEDERAL SIGNAL
Safety and Security Systems

2645 Federal Signal Drive
University Park, Illinois 60484

www.fedsig.com

Customer Support 800-548-7229 • +1 708 534-3400
Technical Support 800-524-3021 • +1 708 534-4790

All product names or trademarks are properties of their respective owners.

Contents

Safety Messages	5
General Description	8
Overview	8
Features.....	9
Contactor Activation	9
Radio Control	9
Battery Backup.....	9
Specifications	9
Unpacking the Kit	10
Installation	11
Locating the Transformer	11
Preliminary	13
Installation Requirements	13
Mounting on a Pole	13
Mounting on a Flat Surface.....	14
Electrical Connections	17
Connecting the Transformer/Rectifier	18
Connecting the Contactor Enclosure	19
Connecting the Siren	20
Connecting the Control Unit (Optional).....	20
Maintenance	21
Testing.....	21
Inspection.....	21
Troubleshooting	21
Getting Technical Support and Service	23

Tables

Table 1 Specifications	9
Table 2 Physical	10
Table 3 Enclosure	10
Table 4 2001TRB/2001TRBP Contents.....	11

Figures

Figure 1 2001-AC Components	8
Figure 2 Typical Siren Installation Drawing	12
Figure 3 Contactor Enclosure Assembly Drawing	15
Figure 4 Transformer/Rectifier	16
Figure 5 Typical Wiring Diagram.....	17
Figure 6 Transformer/Rectifier Schematic Diagram.....	19
Figure 7 Terminal Block in Siren.....	19

Safety Messages

⚠ WARNING

It is important to follow all instructions shipped with this product. This device is to be installed by trained personnel who are thoroughly familiar with the country's electric codes and will follow these guidelines as well as local codes and ordinances, including any state or local noise-control ordinances.

Listed below are important safety instructions and precautions you should follow.

Important Notice

Federal Signal reserves the right to make changes to devices and specifications detailed in the manual at any time in order to improve reliability, function, or design. The information in this manual has been carefully checked and is believed to be accurate; however, no responsibility is assumed for any inaccuracies.

Publications

Federal Signal recommends the following publications from the Federal Emergency Management Agency for assistance with planning an outdoor warning system:

- The "Outdoor Warning Guide" (CPG 1-17)
- "Civil Preparedness, Principles of Warning" (CPG 1-14)
- FEMA-REP-1, Appendix 3 (Nuclear Plant Guideline)
- FEMA-REP-10 (Nuclear Plant Guideline)

Planning

- If suitable warning equipment is not selected, the installation site for the siren is not selected properly, or the siren is not installed properly, it may not produce the intended optimum audible warning. Follow Federal Emergency Management Agency (FEMA) recommendations.
- If sirens are not activated in a timely manner when an emergency condition exists, they cannot provide the intended audible warning. It is imperative that knowledgeable people, who are provided with the necessary information, be available at all times to authorize the activation of the sirens.
- When sirens are used out of doors, people indoors may not be able to hear the warning signals. Separate warning devices or procedures may be needed to warn people indoors effectively.
- The sound output of sirens can cause permanent hearing damage. To prevent excessive exposure, carefully plan siren placement, post warnings, and restrict access to areas near sirens. Review and comply with any local or state noise control ordinances as well as OSHA noise exposure standards, regulations, and guidelines.
- Activating the sirens may not result in people taking the desired actions if those to be warned are not properly trained about the meaning of siren sounds. Siren users should follow FEMA recommendations and instruct those to be warned of corrective actions to be taken.

- After installation, service, or maintenance, test the siren system to confirm that it is operating properly. Test the system regularly to confirm that it will be operational in an emergency.
- If future service and operating personnel do not have these instructions to refer to, the siren system may not provide the intended audible warning, and service personnel may be exposed to death, permanent hearing loss, or other bodily injuries. File these instructions in a safe place and refer to them periodically. Give a copy of these instructions to new recruits and trainees. Also give a copy to anyone who is going to service or repair the siren.

Installation and Service

- Electrocution or severe personal injury can occur when performing various installation and service functions such as making electrical connections, drilling holes, or lifting equipment. Therefore, only experienced and qualified electricians should install this product in compliance with national, state, and any other applicable codes, ordinances, and regulations. Perform all work under the direction of the installation or service crew safety foreman.
- The sound output of sirens is capable of causing permanent hearing damage. To prevent excessive exposure, carefully plan siren placement, post warnings, and restrict access to areas near the sirens. Sirens may be operated from remote control points. Whenever possible, disconnect all siren power, including batteries, before working near the siren. Review and comply with any local or state noise control ordinances as well as OSHA noise exposure regulations and guidelines.
- After installation or service, test the siren system to confirm that it is operating properly. Test the system regularly to confirm that it will be operational in an emergency.
- If future service and operating personnel do not have these instructions to refer to and are not properly trained, the system may not provide the intended audible warning, and service personnel may be exposed to hazards that could result in death, permanent hearing loss, or other bodily injuries. File these instructions in a safe place and refer to them periodically. Give a copy of these instructions to recruits and trainees. Also give a copy to anyone who is going to service or repair the siren.

Operation

Failure to understand the capabilities and limitations of your siren could result in permanent hearing loss, other serious injuries, or death to persons too close to the sirens when you activate them or to those you need to warn. Carefully read and thoroughly understand all safety notices in this manual and all operations-related items in all instruction manuals shipped with the equipment. Thoroughly discuss all contingency plans with those responsible for warning people in your community, company, or jurisdiction. A well-written contingency plan document is recommended.

Hazard Classification

Federal Signal uses signal words to identify the following:

⚠ DANGER

DANGER indicates a hazardous situation which, if not avoided, will result in death or serious injury.

⚠ WARNING

WARNING indicates a hazardous situation which, if not avoided, could result in death or serious injury.

⚠ CAUTION

CAUTION indicates a hazardous situation which, if not avoided, could result in minor or moderate injury.

NOTICE

NOTICE is used to address practices not related to physical injury.

Read and understand the information contained in this manual before attempting to deploy or service the siren.

Pay careful attention to notices located on the equipment.

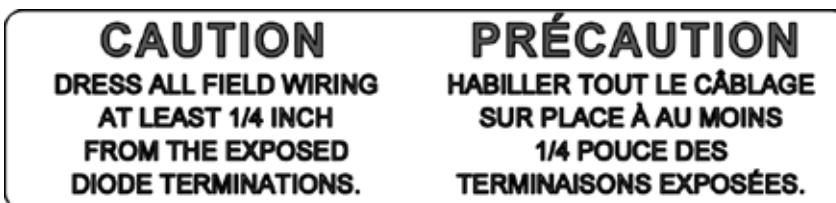

General Description

Overview

Federal Signal has a variety of hardware to power and control mechanical 48 Vdc powered sirens. The 2001-AC is a power and control system for mechanical-type sirens. The 2001-AC consists of a nominal 220 Vac-to-48 Vdc Transformer Rectifier for power and a Contactor Enclosure with fusing and contactors for switching power to a siren. Activate the contactors by a simple switch, equipment using landlines, IP using IP network devices, or by radio with Federal Signal FC Controllers. Typical 2001-AC systems are one-way systems with no reporting or monitoring. In addition, 2001-AC systems are typically reliant on the AC power grid for power. Loss of AC power results in no siren activation. For life safety, Federal Signal recommends using the DCFCTBD system with two-way system monitoring and battery backup in case of AC power loss.

The 2001-AC converts 208/220/240 Vac to nominal 48 Vdc and provides relay contactors to switch 48 Vdc to external equipment (such as a siren).

The 2001-AC consists of two enclosures that you can separately mount for ease of installation. (See Figure 1.) The 2001-AC consists of the following:

- NEMA4 enclosure with two contactors for chopper and rotate motors (Contactors are commonly referred to as motor starters.)
- Transformer/Rectifier (rainproof)

The Contactors Enclosure switches 48 V power to the siren and rotator motors from the Transformer/Rectifier. The Transformer/Rectifier enclosure contains the step-down Transformer/Rectifier, which provides the 48 Vdc for powering the siren.

Figure 1 2001-AC Components

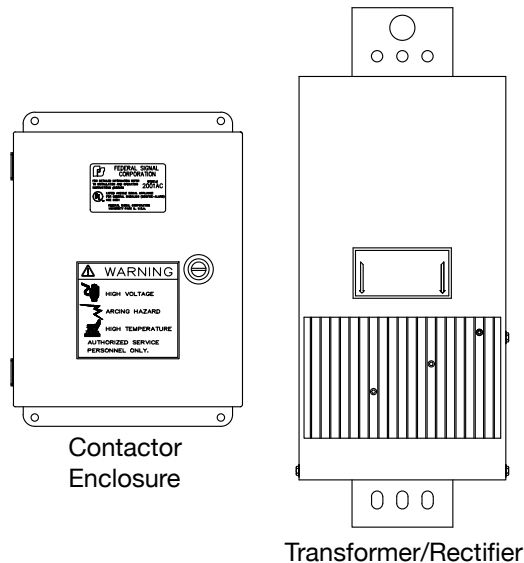

Features

The 2001-AC has the following features:

- Operates from either 208, 220, or 240 Vac single phase, 50-60 Hz
- Contactor enclosure is supplied with a padlock hasp for security
- Provides 115 Vdc for optional AC accessories

Contactors Activation

You can control the contactors by any device with relay or transistor outputs with a rating of at least 1 ampere, 50 Vdc (for example, an FC Controller).

Radio Control

You can remotely activate the contactors by a radio signal when an FC Controller is used. Activation by radio control has the advantage that physical control lines are not required. The FC Controllers are capable of both radio and local button control. These controllers are available in UHF and VHF bands. Landline, cellular, satellite, and IP options are available. Contact your local Federal Signal representative for further information. See Getting Technical Support and Service.

Battery Backup

You can upgrade the 2001-AC to a battery-backed system, which automatically switches from AC primary operation to DC backup operation in the event of a power failure. Contact your local Federal Signal representative for further information on battery backup systems. See Getting Technical Support and Service.

Specifications

Table 1 Specifications

Electrical Requirements for the Transformer/Rectifier	
Rated Capacity	6.5 KVA
Rated Frequency	50-60 Hz
Input Voltage	208/220/240 Vac (+/- 10%), single phase
Input Current	40/38/36 A
Output Voltage	46 Vdc at 130 A dc 115 Vac at 10 A ac
Max. Continuous runtime	15 min
Max. Duty cycle	50%
Contactors	
Contact Rating	200 A at 48 Vdc
Coil	48 Vdc, 110 Ω
Contact Fusing	200 A (fast)
Environmental	
Operating Temperature	30° to +65°C (-22° to 149°F)
Humidity	0-98% Non-Condensing

Table 2 Physical

Contacting Enclosure	NEMA4
Contacting Enclosure Dimensions (H x W x D)	13.5 x 10 x 6 in (34.3 x 25.4 x 15.3 cm)
Contacting Weight	16.0 lb (7.2 kg)
Transformer/Rectifier	Rainproof
Transformer/Rectifier Dimensions (H x W x D)	25.8 x 10.2 x 13.6 in (65.5 x 25.9 x 34.5 cm)
Transformer/Rectifier Weight	157 lb (71.2 kg)

Unpacking the Kit

Ensure that the parts listed are included in the package. If you are missing any parts, contact Customer Support. See Getting Technical Support and Service.

Table 3 Enclosure

Required	Description	Part Number
1	NEMA4 cabinet	170314A
1	Mtg. plate	8574025A
2	Contacting	131A183C
1	200 A Fuse	148A147A
2	Term. block Fuse	8402A066A
4	Screw, Thd Frm #8	7011A101-12
1	Buss Bar	8402109A
4	Screw, Thd Frm #8	7011A069-06
6	Screw, Pan head, 4-40	7000444-05
6	Int, Tooth, Lock Washer	7075A080
1	Buss Bar	8402096A
1	Flat Washer	7072A032
4	Keps nut, 5/16-18	7058A033
1	Plug, Hole, Ø1.38 inches	231194-01
1	Snubber Cap, PCBA	20000216

Table 4 2001TRB/2001TRBP Contents

Description	2001TRB/2001TRBP includes	2001TRB/2001TRBP Service Part Number
Transformer rectifier	120246F-AL	Q120246F-AL
48 Vdc Contactor	131A182C	Q131A182C
Fused wire	1461132A	
Snubber	20000216	
Pan Head screw (2)	7011A069-08	
Brass washer	70700520	
Two position buss bar	8402109A	
Buss bar rt angle	8402138A	
Diode Rectifier	115336A	Q115336A

Installation

▲ DANGER

ELECTROCUTION HAZARD: Electrocution or severe personal injury can occur when making electrical connections, drilling holes, or lifting equipment. Therefore, experienced electricians, per national and local electrical codes, acting under the direction of the installation crew safety foreman, should perform the installation.

Locating the Transformer

Mount the transformer assembly as close as possible to the control unit to keep cabling distances as short as possible.

See "Table 2 Physical" on page 10 for the size and weight of the various components. Ensure that the mounting surface and fasteners can safely sustain the weight.

▲ CAUTION

INSTALLATION PRECAUTIONS: The 2001TRB/2001TRBP transformer must be permanently mounted. All wiring must be run in a sealed conduit. The transformer may become hot during extended use and should be installed so that it is not likely to be contacted by people.

Figure 2 Typical Siren Installation Drawing

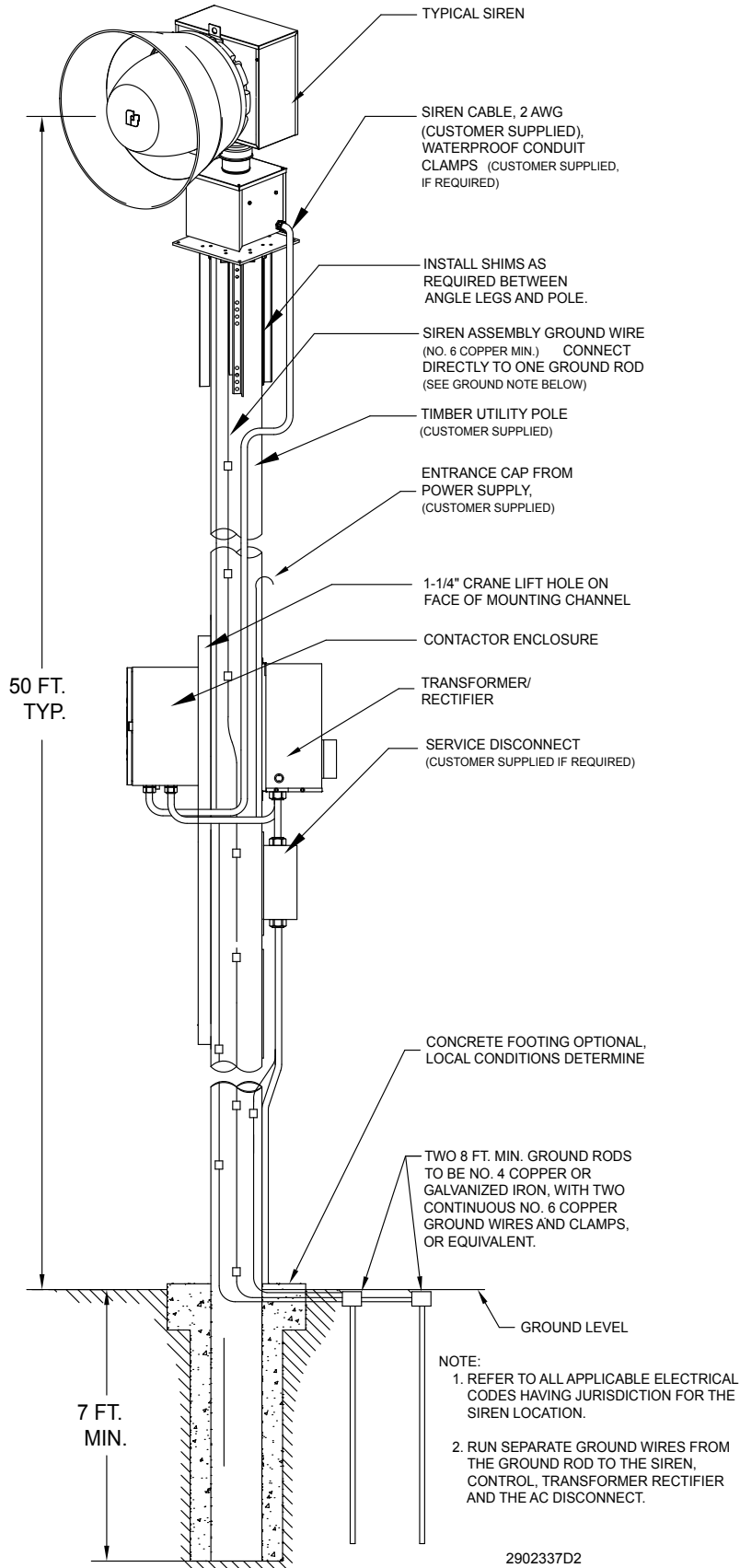

Preliminary

Carefully inspect the unit for damage that may have occurred in transit. If there is any physical damage to the unit or components, notify the carrier immediately, stating the extent of the damage.

Installation Requirements

▲ CAUTION

INSTALLATION PRECAUTIONS: Use good installation methods and follow local ordinances for mounting the cabinet.

Mounting on a Pole

The 2001-AC components are typically mounted on a pole. A typical installation showing the relative location of the controller is illustrated in Figure 2. There are numerous methods to use to mount the 2001-AC components. In all cases, the installation must be rigid, secure, and free from physical shock or vibration.

Mount the Contactors Enclosure and Transformer/Rectifier separately. There are predrilled mounting holes in each enclosure.

To attach the Contactors Enclosure and Transformer/Rectifier to the pole:

1. Use proper lifting equipment to lift the enclosures to the desired height along the pole. Attach the Contactors to the pole at a height accessible to service personnel but that discourages vandalism.
2. Use the proper lifting equipment to hold the components against the pole. Using the holes in each enclosure as a template, locate the holes on the pole.

Transformer/Rectifier

3. Transformer/Rectifier—Drill a 3/8-inch hole at all mounting locations. Drill each hole at least 3-1/2 inches (90 mm) deep.
4. Attach the Transformer/Rectifier Enclosure to the pole; use a minimum of three user-supplied 1/2 by 5-inch lag bolts. Slide a user-supplied 1/2-inch flat washer onto each bolt before threading the bolt into the pole.

Contactors Enclosure

5. Contactors Enclosure—Attach the enclosure to the pole using four user-supplied 1/4 by 3-inch lag bolts. Be careful not to bend the enclosure around a small diameter pole.
6. Mount a user-supplied fused disconnect switch, per local and national electric codes, on the pole beneath or opposite the Transformer/Rectifier assembly in line with the primary AC service.

Mounting on a Flat Surface

To attach the Contactor Enclosure and Transformer/Rectifier to a flat surface:

1. The 2001-AC components are mounted separately. There are predrilled mounting holes in each enclosure for attaching the enclosures to a wall or other substantial vertical surface. If the siren is installed on the roof of the building, it may be desirable to install the 2001-AC components inside the building if practical.
2. Install a user-supplied, fused disconnect switch per National and Local Electrical Codes in line with the primary AC service.

⚠ CAUTION

INSTALLATION PRECAUTIONS: Use good mounting practices and consult a structural engineer if required.

Figure 3 Contactor Enclosure Assembly Drawing

ITEM	REQ'D	PART NO.	DESCRIPTION
1	1	170314A	CBNT, NEMA4
2	1	8574025A	MTG. PLATE
3	2	131A183C	CONTACTOR
4	1	148A147A	FUSE, 200 AMP
5	2	8402A066A	FUSE/TERM BLOCK
6	4	7011A101-12	SCREW, THD FRM, #8
7	1	8402109A	BUSS BAR
8	4	7011A069-06	SCREW, THD FRM, #8
9	6	7000444-05	SCREW, PAN HD, 4-40
10	6	7075A080	INT. TTH. LOCK WASHER
11	1	8402096A	BUSS BAR
12	1	7072A032	WASHER, FLAT
13	4	7058A033	NUT, KEPS, 5/16-18
14	1	231194A-01	PLUG, HOLE, ϕ 1.38"
15	1	20000216	SNUBBER CAP, PCBA

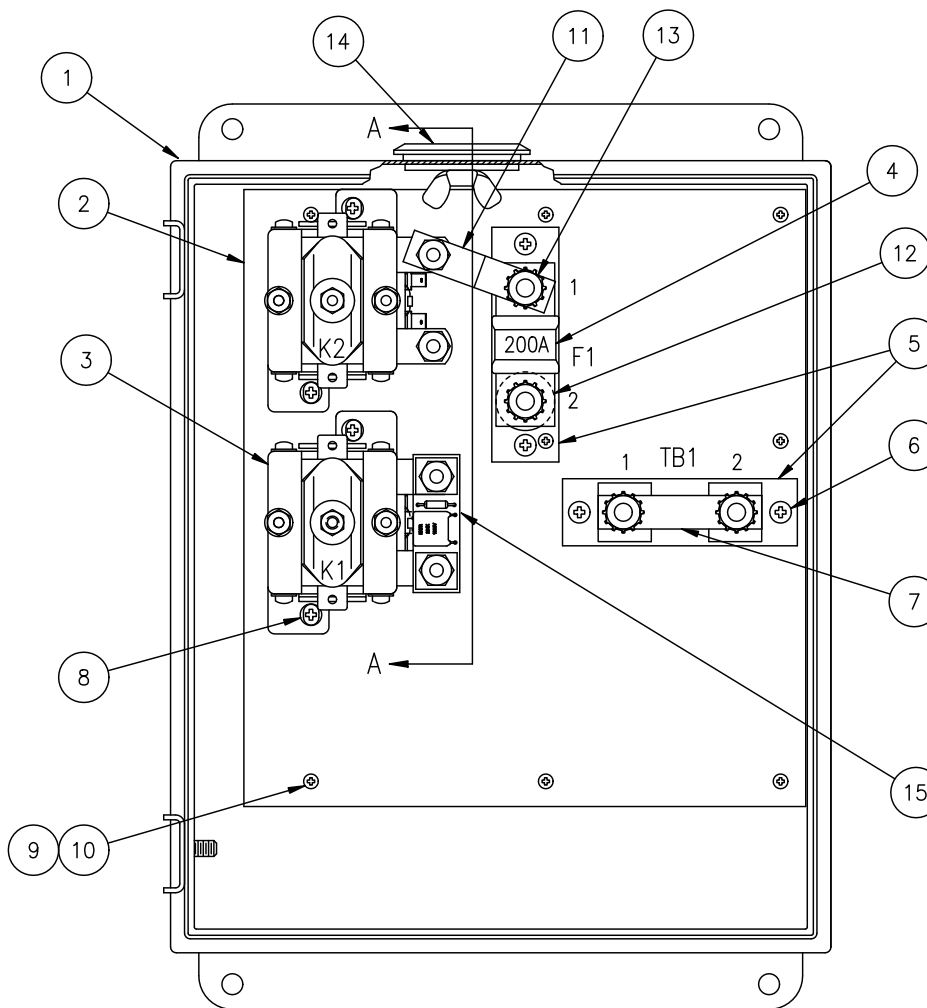
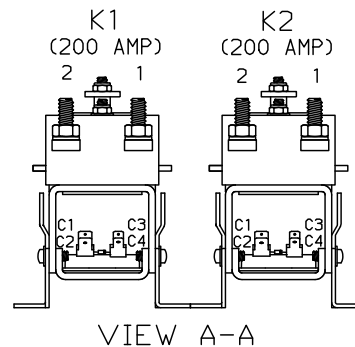

291140E

Figure 4 Transformer/Rectifier

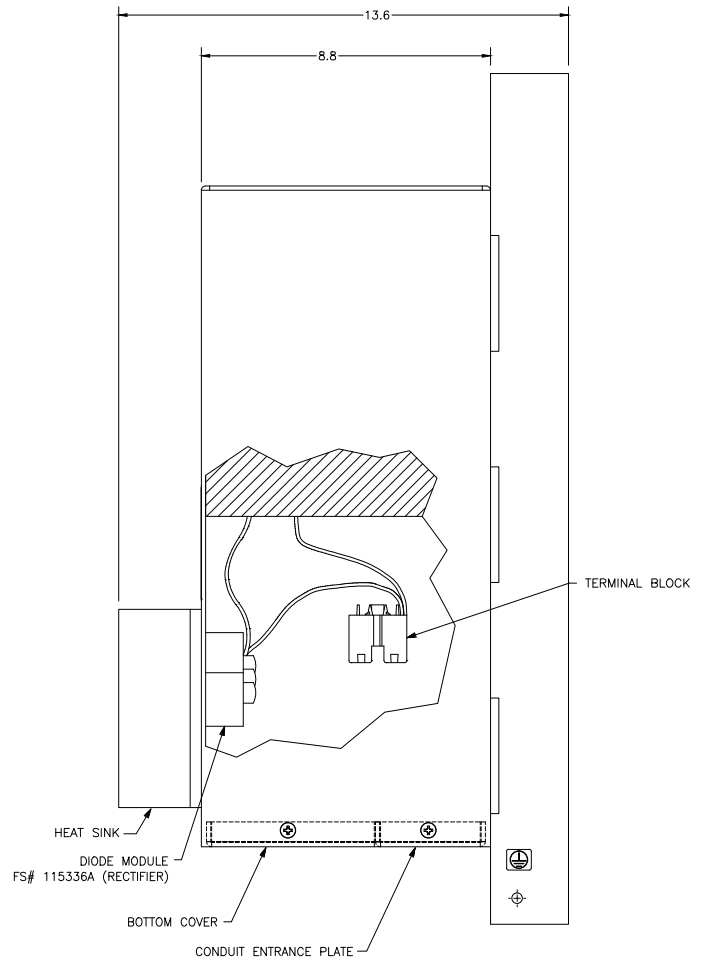
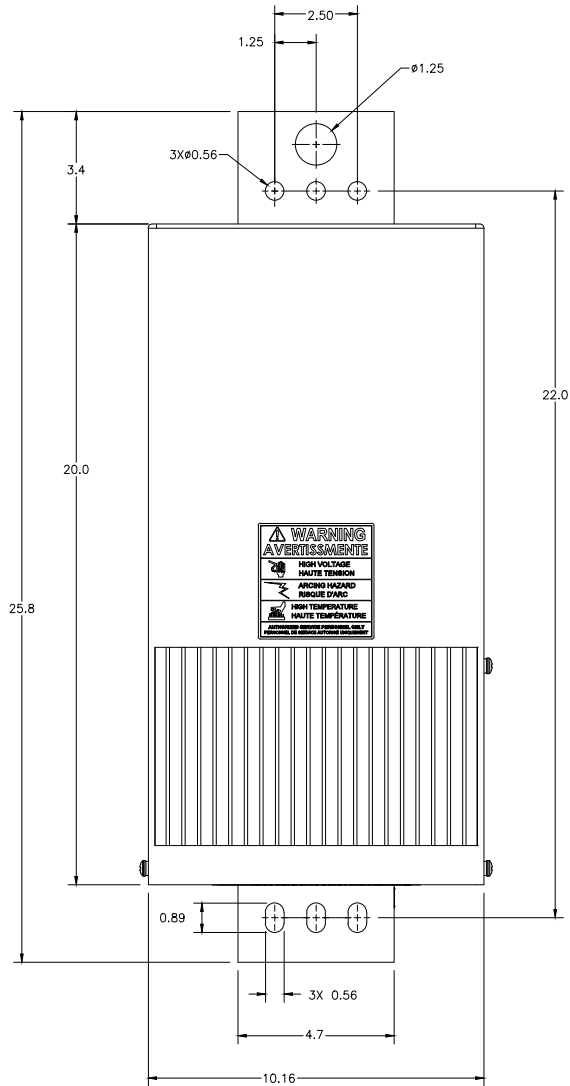
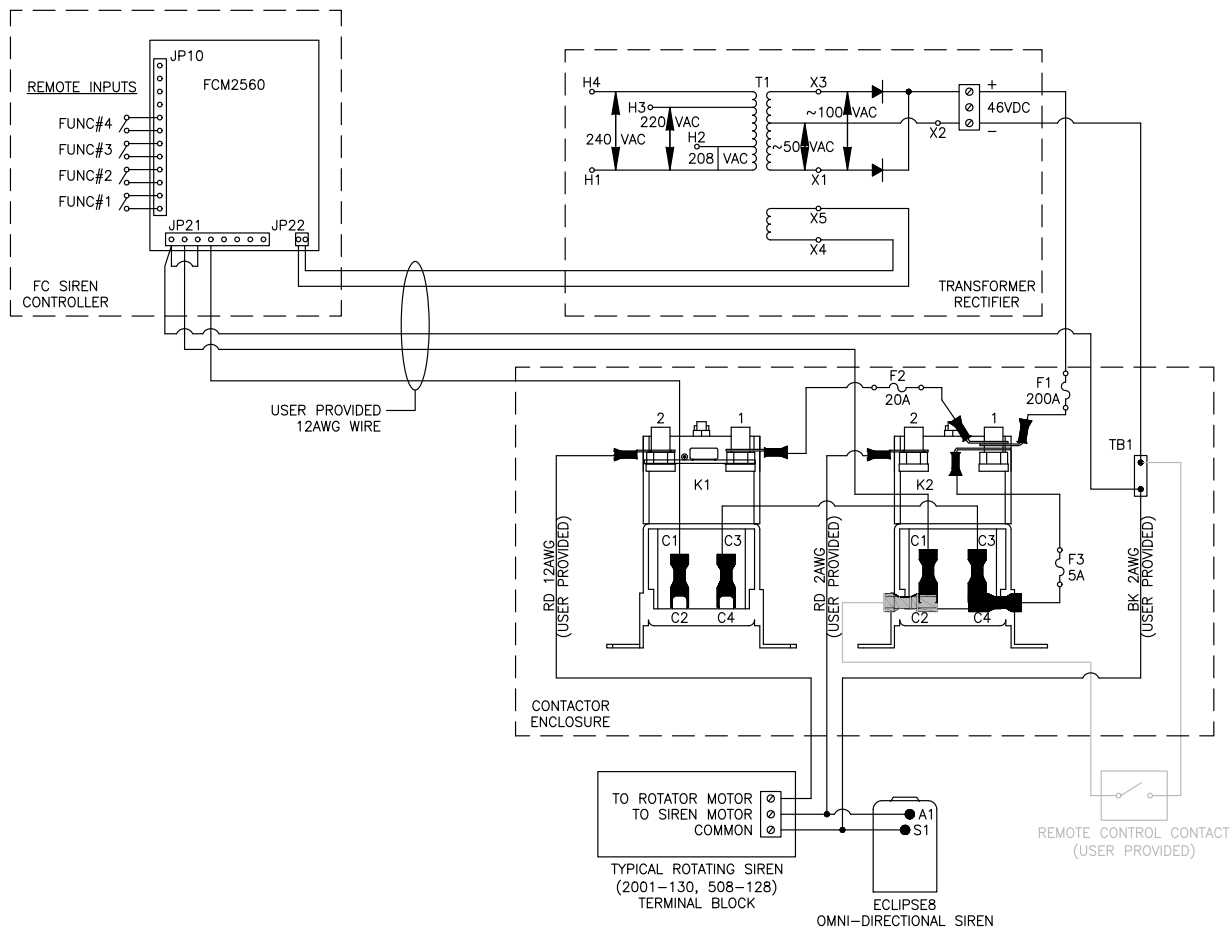

Figure 5 Typical Wiring Diagram



Electrical Connections

⚠ WARNING

SHOCK HAZARD: Install the siren electrical system in compliance with local electrical codes and NEC recommendations. Federal Signal also recommends that all user-installed conduit connections enter from the bottom of the cabinet. Disconnect all power and read all warnings at the beginning of this manual and before making connections.

⚠ CAUTION

SHOCK HAZARD: The UV controller must be solidly connected to an earth ground. If the siren is installed in a building, ground the system to a metallic object known to be grounded. For pole mount installations, drive a metal rod or bar at least eight feet into the ground, as close as practical to the base of the pole. Use a separate, continuous 6 AWG or larger wire from the siren frame to ground and from the cabinet of each siren control system to ground.

Connecting the Transformer/Rectifier

⚠ DANGER

SHOCK HAZARD: Disconnect AC power and make sure the Transformer is de-energized before making or changing electrical connections. Failure to do so may result in property damage, serious injury, or death.

To connect the Transformer/Rectifier:

1. Route 1-inch conduit between the user-supplied fused disconnect switch and the user-supplied conduit fitting at the bottom of the Transformer/Rectifier enclosure.
2. Route two user-supplied wires through the conduit that was just installed between the Transformer/Rectifier and the fused disconnect switch. Use 10 AWG or larger. Connect the power wires as follows:
 - H1-H2 for 208 Vac
 - H1-H3 for 220 Vac
 - H1-H4 for 240 Vac(See "Figure 6 Transformer/Rectifier Schematic Diagram" on page 19.) Cap the unused taps.
3. Follow the instructions included with the lightning protector (supplied) and install it in the AC service disconnect.
4. Route 1-inch conduit between the Transformer/Rectifier Enclosure and the Contactor Enclosure.
5. Route two user-supplied wires through the conduit that was just installed between the Transformer/Rectifier and Contactor Enclosure. Use 3 AWG or larger.
6. Connect a red or (+) labeled wire from the Transformer/Rectifier terminal block (+) to F1-2 of the Contactor Enclosure (user-supplied 5/16-inch ring terminal required).
7. Connect a black or (-) labeled wire from the Transformer/Rectifier terminal block (-) to TB1 2 of the Contactor Enclosure (user-supplied 5/16-inch ring terminal required).
8. Remove any metal shavings or debris from the enclosures.
9. Ground the Transformer/Rectifier enclosure to earth ground.

Figure 6 Transformer/Rectifier Schematic Diagram

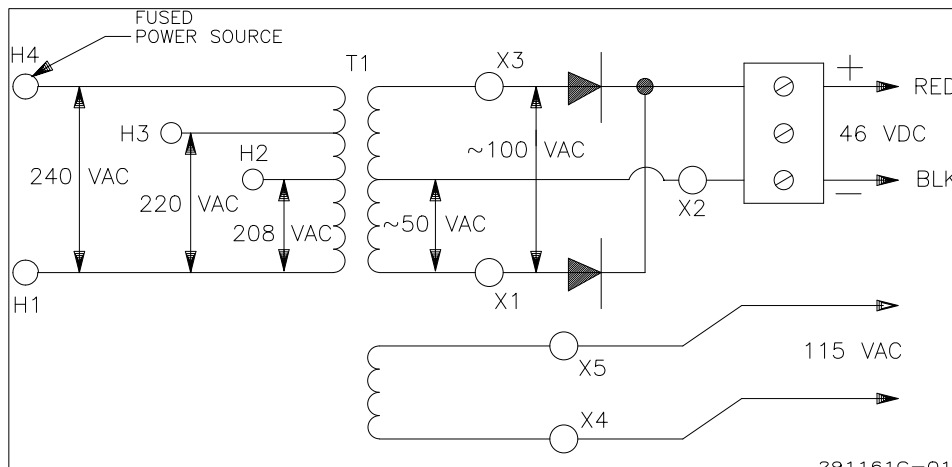

Connecting the Contactor Enclosure

To connect the siren to the Contactor Enclosure:

1. After drilling or punching an appropriate-sized hole in the enclosure, install a 1-inch user-supplied electrical conduit fitting in the bottom of the enclosure and at the bottom of the siren rotator housing.
2. Install a 1-inch user-supplied electrical conduit between the conduit fitting in the bottom of the siren rotator housing and the conduit fitting at the bottom of the Contactor Enclosure.
3. Route the two 2-AWG siren motor wires and the one 12-AWG rotator motor wire (user-supplied) from the siren rotator housing to the Contactor Enclosure through the conduit.
4. Connect the 12 AWG wire (48 Vdc) from the terminal block in the rotator housing terminal 1 to the rotator control relay K1-2 (user-supplied 1/4-inch ring terminal required). (See Figure 3, View A-A).

Figure 7 Terminal Block in Siren

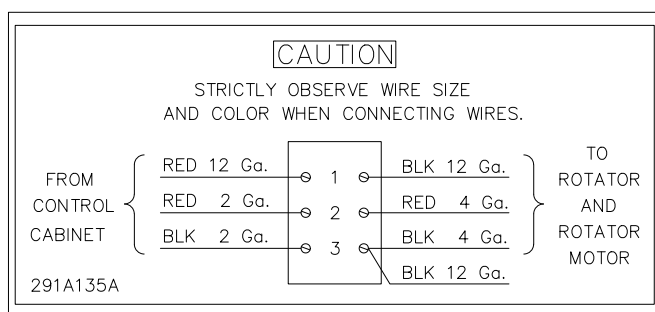

5. Connect a 2 AWG wire (48 Vdc) from the terminal block in the rotator housing terminal 2 to the rotor control relay K2-2 (user-supplied 1/4-inch ring terminal required).
6. Connect a 2 AWG wire (common) from the terminal block in the rotator housing terminal 3 to TB1-1 in the control box (user-supplied 5/16-inch ring terminal required).
7. Tighten all connections securely to provide good electrical connections.

8. Remove any metal shavings or debris from the enclosures.
9. Ground the Siren and 2001-AC enclosure to earth ground.
10. Bond the Siren, 2001-AC, and 2001TRB/2001TRBP to earth ground using separate continuous runs of 6 AWG minimum gauge wire. (Do not “T” from another ground wire.)

Connecting the Siren

The 2001-AC parts list and wiring diagrams are shown in Figures 3 through 5.

- Typical connections between the siren and control unit are accomplished using user-supplied wires. Two 2 AWG wires provide operating power to the siren motor. An additional 12 AWG wire provides operating power to the rotator motor if required.
- Route the interconnecting cable through the conduit between the siren and the Contactor Enclosure. A three-position terminal block in the siren housing accepts stripped wire.
- In the Contactor Enclosure, the DC GROUND terminal block TB1 accepts user-supplied 5/16-inch ring terminals, and the relays accept user-supplied 1/4-inch ring terminals. The contactor coils accept user-supplied 1/4-inch spade terminals. These points provide convenient locations for making all electrical connections.

Connecting the Control Unit (Optional)

The siren controller (purchased separately) must provide a contact closure between each contactor (K1 and K2) coil and the DC ground, TB1. K2 controls the main siren motor and can be held on steady or pulsed on and off for various siren sounds. K1 controls the siren rotator motor and must be held on for the duration of the siren signal if siren rotation is required.

Connections to the contactor coils of K1 and K2 are made at the C1 positions of each coil using 1/4-inch spade terminals. (See Figure 3, view A-A.)

Federal Signal FC Controllers are recommended. See the FC, FCH, and FCU Models Manual (part number 255294) for installation instructions.

Maintenance

Testing

Federal Signal recommends periodic testing of these systems to ensure the operation is performing as expected. Users should define the appropriate schedule for testing. FEMA can be used to identify good practices for periodic testing requirements.

Inspection

⚠ WARNING

SOUND HAZARD: Service or maintenance should be performed by qualified personnel familiar with the siren, associated controls, and power sources being used and in conjunction with the authorities having jurisdiction.

The sound output of sirens is capable of causing severe hearing discomfort or permanent hearing damage. Therefore, always wear hearing protection when performing tests or maintenance on the siren and avoid excessive exposure.

To inspect the controller:

1. Turn off AC power.
2. For the siren, visually inspect the siren air intakes and sound outlets for obstructions.
3. Ensure all connections in the Control Unit, Siren, Contactors, and Transformer/Rectifier are correct and properly tightened.
4. Turn on AC power.
5. Activate the wail function. Check for proper rotation and sound of the siren. After confirming that the installation is complete and it has been established that the siren is operating properly, Federal Signal recommends that all control devices be padlocked to discourage tampering and vandalism.

Troubleshooting

NOTE: It is normal for the 46 Vdc output of the transformer to have 20-30 V_{rms} of AC ripple without load. With load, the AC ripple significantly decreases.

If the 46 Vdc output of the transformer is about half of 46 Vdc, the typical cause is a defective Diode Rectifier or Transformer. Lightning or a power surge may have damaged the Diode Rectifier or Transformer.

1. Turn off the AC power to the transformer. Verify that AC power has been turned off.
2. Disconnect wires X1 and X3 from the Diode Rectifier and carefully protect the wires from shorting.
3. Connect the voltmeter to X1 and X3. Turn on AC power and measure X1 and X3. They should measure about 100 Vac.
4. Turn off the AC power to the transformer. Verify that the AC power has been turned off.
5. Connect the voltmeter to X1 and X2. Turn on AC power and measure X1 and X2. They should measure about 50 Vac.

Troubleshooting

- 6.** Turn off the AC power to the transformer. Verify that AC power has been turned off.
- 7.** Connect the voltmeter to X3 and X2. Turn on AC power and measure X3 and X2. They should measure about 50 Vac.

If the voltages above are incorrect, the entire transformer part number Q120246F-AL will need to be replaced.

If the voltages above are correct, the Diode Rectifier part number Q115336A will need to be replaced.

Getting Technical Support and Service

For Technical Support, contact:

Federal Signal Technical Support
Phone: 800-524-3021 or 708-534-4790
Email: techsupport@fedsig.com
www.fedsig.com

For Customer Support, contact:

Federal Signal Customer Support
Phone: 800-548-7229 or 708-534-3400 extension 367511
Email: customersupport@fedsig.com
www.fedsig.com



FEDERAL SIGNAL
Safety and Security Systems

2645 Federal Signal Drive
University Park, Illinois 60484

www.fedsig.com

Customer Support 800-548-7229 • +1 708 534-3400
Technical Support 800-524-3021 • +1 708 534-4790