

210990 C1 0720

Safety Message to Installers and Service Personnel of Backup Alarms

▲ WARNING

People's lives depend on your safe installation of our products in conformance with our instructions. It is necessary to read, understand and follow all instructions shipped with the products. Listed below are some other important safety instructions and precautions you should follow.

- To properly install the equipment described in this instruction sheet, you must have a good understanding of automotive electrical procedures and systems, along with proficiency in the installation and use of safety warning equipment.
- When drilling into a vehicle structure, ensure that both sides of the surface are clear of anything that could be damaged.
- Locate the Backup Alarm so it will operate safely under all conditions. The location must provide protection from impact and adverse weather conditions while allowing unobstructed sound projection to the target hazard area.
- All effective Backup Alarms produce loud sounds that may cause, in certain situations, permanent hearing loss. You should take appropriate precautions such as wearing hearing protection.
- Ensure that the vehicle's supply voltage is within the voltage rating specified on the Backup Alarm.
- Frequently inspect the Backup Alarm system to ensure that it is operating properly and that it is securely attached to the vehicle.
- File these instructions in a safe place and refer to them when maintaining and/or reinstalling the product.

Failure to follow all safety precautions and instructions may result in property damage, serious injury or death to you or others you are seeking to protect.

Introduction

These Reversible Polarity Backup Alarms are lightweight, low current, piezo-electric, solid-state audible warning devices. They can generate two distinct

warning tones—a pulsed (beeping) tone and a constant tone. The tone is changed by reversing the polarity of the connections to the power source. The housing is environmentally sealed against moisture, dust, and corrosion.

The compact design only requires 6.7 square inches of surface area for mounting. All units are supplied with a heavy-gauge plated steel universal mounting bracket.

Table 1 Specifications

Operating Voltage	9-48 Vdc
Operating Current	0.15 A at 12 Vdc
Pulse Frequency	80 Beeps per minute ± 20
Frequency	2400 Hz ± 400 Hz
Temperature Range	-40°F to 165°F (-40°C to +74°C)

NOTE: The units are protected against voltage spikes. Reverse polarity activates the constant tone.

Unpacking the Kit

After unpacking the kit, inspect it for damage that may have occurred in transit. If it has been damaged, do not attempt to install or operate it. File a claim immediately with the carrier, stating the extent of the damage. Carefully check all envelopes, shipping labels, and tags before removing or destroying them. Ensure that the parts in Table 2 are included in the package. If you are missing any parts, contact Customer Support at 1-800-264-3578, 7 a.m. to 5 p.m., Monday through Friday (CT).

Table 2 Kit Contents List

Qty	Description	Part No.
1	Mounting Bracket	8435717
2	6-32 x 1/4-inch Pan Head Screw	200316
1	1/4-20 Stainless Steel Hex Head Screw	7000A311-10
2	#6 Internal Tooth Lockwasher	208006
1	Warning Label	200399
2	18-20 Gauge Ring Connector	439570

Installing the Alarm

This alarm is designed to concentrate its audible alarm in the target hazard area. For proper warning signal coverage, the alarm should be mounted approximately 4 feet above ground level with the unit's sound ports facing the target hazard area. There should be no obstructions around or blocking the sound ports of the unit.

Do not mount the alarm with the sound ports facing upwards, where it can become buried, submerged or clogged with mud, water and other debris. A clogged alarm will be rendered ineffective and produce little or no sound output. Make sure the alarm's sound ports are facing the area you are trying to warn, the ports are not clogged, and the alarm is functioning properly before using the vehicle.

Select a mounting location at the rear of the vehicle that will provide protection from impact and adverse weather conditions while allowing unobstructed sound projection to the target hazard area.

A suggested location is on the rear of the vehicle, just inside the last cross member or other sturdy part of the body structure. The supplied "L-type" mounting bracket provides mounting flexibility and allows installation in a variety of locations.

Making the Electrical Connections

1. Terminate one end of a user-supplied red (or white) 18 gauge wire with a supplied #6 ring terminal. Terminate one end of a user-supplied black 18 gauge wire with the other #6 ring terminal.
2. To generate the pulsed (beeping tone) using a #6-32 x 1/4" screw and #6 lockwasher, connect the red (or white) wire to the "+" terminal on the alarm. Using a #6-32 x 1/4" screw and #6 lockwasher, connect the black wire to the "-" terminal on the alarm.

To generate a constant tone, connect the red (or white) wire to the "-" terminal and the black wire to the "+" terminal.

3. Route the other end of the red (or white) wire to the vehicle's backup light circuit, or to an independent actuating switch. DO NOT connect the red (or white) wire to the backup-light circuit, or to the independent actuating switch, at this time.

⚠ WARNING

GROUNDING: Improper grounding could cause the alarm to function improperly, resulting in death or serious injury to those who rely on this device for safety. The ground connection (-) must be attached to a solid metal body or chassis part that will provide a dependable ground path for as long as the device is to be used.

4. Connect the other end of the black wire through the rubber grommet to a known good chassis ground.

Bracket Mounting

1. Using the bracket as a template, scribe four drill position marks on the mounting surface.

Figure 1 Bracket mount exploded view

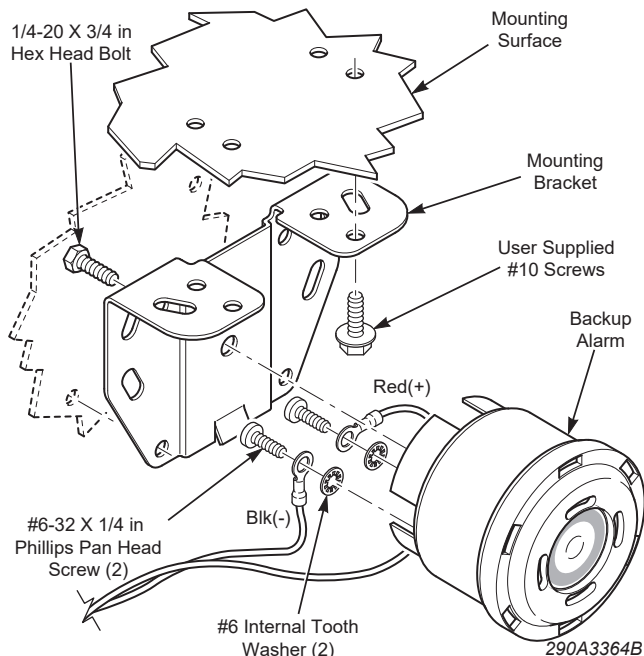

NOTICE

DRILLING PRECAUTIONS: When drilling holes, check the area into which you are drilling to ensure that you do not damage vehicle components. All drilled holes should be deburred, and all sharp edges should be smoothed. All wire routing going through drilled holes should be protected by a grommet or convolute/split-loom weaving.

2. Drill four mounting holes (size determined by the user-supplied mounting bolts) at the drill position marks.
3. Attach the alarm to the mounting bracket using the 1/4-20 by 3/4-inch hex head bolt and tighten the bolt completely into the alarm. Ensure that the wires are not pinched between the bracket and the alarm.
4. Secure the bracket/alarm assembly to the mounting surface with user-supplied #10 screws.

Surface Mounting

1. Scribe a drill position mark at the desired location.

NOTICE

DRILLING PRECAUTIONS: When drilling holes, check the area into which you are drilling to ensure that you do not damage vehicle components. All drilled holes should be deburred, and all sharp edges should be smoothed. All wire routing going through drilled holes should be protected by a grommet or convolute/split-loom weaving.

2. Drill a 0.281-inch hole in the mounting surface.
3. Attach the alarm to the mounting surface using the 1/4-20 by 3/4-inch hex head bolt and tighten the bolt completely into the alarm. Ensure that the wires are not pinched between the mounting surface and the alarm.

Figure 2 Surface mount exploded view

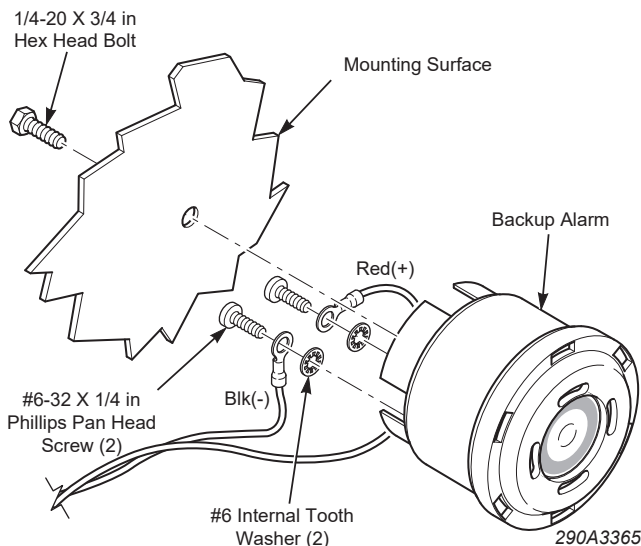

Final Installation and Testing

1. Connect the red (or white) wire to the vehicle's backup light circuit, or to an independent actuating switch. See Figure 3.

Figure 3 Wiring

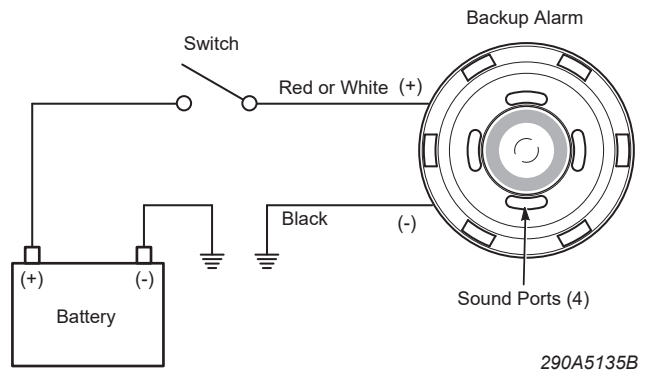

2. Install the WARNING label in a location clearly visible to the operator at all times.

⚠ WARNING

SOUND HAZARD: All effective sirens and horns produce loud sounds (120 dB) that may cause permanent hearing loss. Always minimize your exposure to siren sounds and wear hearing protection. Do not sound the siren indoors or in enclosed areas where you and others will be exposed to the sound.

3. Test the backup alarm for proper operation.

Safety Message to Operators of Backup Alarms

⚠ WARNING

- Do not operate the vehicle if the alarm is inoperative; it could jeopardize the safety or lives of those who depend on the alarm signal for safety.
- All effective Backup Alarms produce loud sounds that may cause, in certain situations, permanent hearing loss. You should take appropriate precautions such as wearing hearing protection.
- Your hearing and the hearing of others, in or close to your vehicle, could be damaged by loud sounds. This can occur from short exposures to very loud sounds, or from longer exposures to moderately loud sounds. For hearing conservation guidance, refer to federal, state, or local recommendations. OSHA Standard 1910.95 offers guidance on "Permissible Noise Exposure."

- Optimum sound propagation will be reduced if the Backup Alarm becomes clogged with a foreign substance such as mud or snow. While cleaning, ensure that foreign material is not packed into the sound ports.
- Although your warning system is operating properly, it may not alert everyone. People may not hear, see, or heed your warning signal. You must recognize this fact and continue to operate your vehicle cautiously.
- Testing the Backup Alarm should be listed on the daily maintenance report. The units on operating vehicles must be tested each day prior to the vehicles' operation. Record results of this test in the maintenance file.
- Notify your supervisor that people operating this equipment **MUST** check for proper operation at the beginning of every shift.
- It is important that you fully understand how to safely operate this warning system before use.

Getting Technical Support

For technical support, please contact:

Federal Signal Corporation
Service Department
Phone: 1-800-433-9132
Email: empserviceinfo@fedsig.com

Getting Repair Service

The Federal Signal factory provides technical assistance with any problems that cannot be handled locally. Any product returned to Federal Signal for service, inspection, or repair must be accompanied by a Return Material Authorization (RMA). Obtain a RMA from a local Distributor or Manufacturer's Representative. Provide a brief explanation of the service requested, or the nature of the malfunction.

Address all communications and shipments to the following:

Federal Signal Corporation
Service Department
2645 Federal Signal Dr.
University Park, IL 60484-3167



2645 Federal Signal Drive
University Park, Illinois 60484-3167

www.fedsig.com

Customer Support
Police/Fire-EMS: 800-264-3578 • +1 708 534-3400
Work Truck: 800-824-0254 • +1 708 534-3400
Technical Support: 800-433-9132 • +1 708 534-3400

© Copyright 2005-2020 Federal Signal Corporation

All trademarks are property of their respective owners.