



Satellite Communication

Model: Q-UV-ISAT2

Description, Configure, and Program Manual

Limited Warranty

This product is subject to and covered by a limited warranty, a copy of which can be found at www.fedsig.com/SSG-Warranty. A copy of this limited warranty can also be obtained by written request to Federal Signal Corporation, 2645 Federal Signal Drive, University Park, IL 60484, email to info@fedsig.com or call +1 708-534-3400.

This limited warranty is in lieu of all other warranties, express or implied, contractual or statutory, including, but not limited to the warranty of merchantability, warranty of fitness for a particular purpose and any warranty against failure of its essential purpose.



FEDERAL SIGNAL Safety and Security Systems

2645 Federal Signal Drive
University Park, Illinois 60484

www.fedsig.com

Customer Support 800-548-7229 • +1 708 534-3400
Technical Support 800-524-3021 • +1 708 534-3400

All product names or trademarks are properties of their respective owners.

Contents

Safety Messages	5
Software Safety Messages	7
General Description	8
Introduction	8
Overview	8
Features.....	8
Ordering Information	9
Qualifications	9
Specifications	9
Required Equipment	10
Required Hardware.....	10
Required Software	10
Satellite Terminal (ST 6100) Required Information	11
Installing and Configuring the Satellite Terminal (ST 6100)	11
1. Installing the Satellite Terminal (ST 6100)	11
2. Confirming the Wiring Connections	12
3. Reading the Signal Strength of the Satellite	14
4. Determining if using Security Code or Encryption Key	18
6. Programming the UV+ Controller card for Satellite Mode	19
6. Programming the FC Controller card for Satellite Mode	22
7. Configuring Commander Software for Satellite Mode	25
Getting Service	27

Tables

Table 1 Ordering Information	9
Table 2 Specifications	9
Table 3 Satellite Terminal (ST 6100) Required Information	11

Figures

Figure 1 Satellite Communications.....	8
Figure 2 Equipment Included in Model Q-UV-ISAT2.....	10
Figure 3 UV+ Backplane Motherboard (JP13).....	12
Figure 4 UV+ Controller RS232-2 (left port)	12
Figure 5 Wiring Connections from Satellite Terminal to the interface board to UV+ controller card.....	13
Figure 6 Satellite interface board.....	14
Figure 7 Modular data cable with the three-way adapter and null modem.....	15
Figure 8 Connecting PC, Universal Programmer, and UV+ controller card.....	20
Figure 9 Connecting PC, Universal Programmer, and FC controller card	23

Safety Messages

⚠ WARNING

It is important to follow all instructions shipped with this product. This device is to be installed by trained personnel who are thoroughly familiar with the country's electric codes and will follow these guidelines as well as local codes and ordinances, including any state or local noise-control ordinances. Listed below are important safety instructions and precautions you should follow.

Important Notice

Federal Signal reserves the right to make changes to devices and specifications detailed in the manual at any time to improve reliability, function, or design. The information in this manual has been carefully checked and is believed to be accurate; however, no responsibility is assumed for any inaccuracies.

Publications

Federal Signal recommends the following publications from the Federal Emergency Management Agency for assistance with planning an outdoor warning system:

- The "Outdoor Warning Guide" (CPG 1-17)
- "Civil Preparedness, Principles of Warning" (CPG 1-14)
- FEMA-REP-1, Appendix 3 (Nuclear Plant Guideline)
- FEMA-REP-10 (Nuclear Plant Guideline).

Planning

- If suitable warning equipment is not selected, the installation site for the siren is not selected properly, or the siren is not installed properly, it may not produce the intended optimum audible warning. Follow Federal Emergency Management Agency (FEMA) recommendations.
- If sirens are not activated promptly when an emergency condition exists, they cannot provide the intended audible warning. It is imperative that knowledgeable people, who are provided with the necessary information, be available at all times to authorize the activation of the sirens.
- When sirens are used out of doors, people indoors may not be able to hear the warning signals. Separate warning devices or procedures may be needed to warn people indoors effectively.
- The sound output of sirens is capable of causing permanent hearing damage. To prevent excessive exposure, carefully plan siren placement, post warnings, and restrict access to areas near sirens. Review and comply with any local or state noise control ordinances and OSHA noise exposure standards, regulations, and guidelines.
- Activating the sirens may not result in people taking the desired actions if those to be warned are not properly trained about the meaning of warning sounds. Users should follow FEMA recommendations and instruct those to be warned of corrective actions to be taken.

- After installation, service, or maintenance, test the siren system to confirm that it operates properly. Test the system regularly to confirm that it will be operational in an emergency.
- If future service and operating personnel do not have these instructions to refer to and are not properly trained, the system may not provide the intended audible warning, and service personnel may be exposed to hazards that could result in death, permanent hearing loss, or other bodily injuries. File these instructions in a safe place and refer to them periodically. Give a copy of these instructions to recruits and trainees.

Installation and Service

- Electrocutation or severe personal injury can occur when performing various installation and service functions such as making electrical connections, drilling holes, or lifting equipment. Therefore, only experienced and qualified electricians should install this product in compliance with national, state, and any other applicable codes, ordinances, and regulations. Perform all work under the direction of the installation or service crew safety foreman.
- The sound output of sirens is capable of causing permanent hearing damage. To prevent excessive exposure, carefully plan siren placement, post warnings, and restrict access to areas near the sirens. Sirens may be operated from remote control points. Whenever possible, disconnect all siren power, including batteries, before working near the siren. Review and comply with any local or state noise control ordinances and OSHA noise exposure regulations and guidelines.
- After installation or service, test the siren system to confirm that it is operating properly. Test the system regularly to confirm that it will be operational in an emergency.
- If future service personnel do not have these instructions to refer to and are not properly trained, the system may not provide the intended audible warning, and service personnel may be exposed to hazards that could result in death, permanent hearing loss, or other bodily injuries. File these instructions in a safe place and refer to them periodically. Give a copy of these instructions to recruits and trainees. Give a copy to anyone who is going to service or repair the sirens.

Operation

Failure to understand the capabilities and limitations of your siren system could result in permanent hearing loss, other serious injuries, or death to persons too close to the sirens when you activate them or to those you need to warn. Carefully read and thoroughly understand all safety notices in this manual and all operations-related items in all instruction manuals shipped with the equipment. Thoroughly discuss all contingency plans with those responsible for warning people in your community, company, or jurisdiction. A well-written contingency plan document is recommended.

Hazard Classification

Federal Signal uses signal words to identify the following:

⚠ DANGER

DANGER indicates a hazardous situation which, if not avoided, will result in death or serious injury.

⚠ WARNING

WARNING indicates a hazardous situation which, if not avoided, could result in death or serious injury.

⚠ CAUTION

CAUTION indicates a hazardous situation which, if not avoided, could result in minor or moderate injury.

NOTICE

NOTICE is used to address practices not related to physical injury.

Read and understand the information contained in this manual before attempting to install or service the siren.

Pay careful attention to notices located on the equipment.

Software Safety Messages

Listed below are important safety instructions and precautions you should follow:

Programming Warning

- Precautions for PC security must be followed. Administrative rights are required.
- Program after reading this manual.
- Only personnel thoroughly familiar with Commander® operating instructions and the intended method of use should perform the programming.
- Correctly program Commander® per the user's specific application before placing it into use.
- If programmed incorrectly, Commander® may fail to operate as intended.
- Test Commander® for proper operation after programming and before placing into use.

General Description

Introduction

This manual describes how to configure the Satellite Terminal (ST 6100) to interface with the UV+ or FC Controller card and then program Commander® software for satellite mode. The programming for the Satellite Terminal requires using the USB Flasher software and Commander® software.

Overview

A satellite terminal is ideal for activating and monitoring sirens when distance and/or geographical barriers are present. The satellite terminal is offered using the IsatData Pro network based on its proven reliability and coverage. Satellite services can be added independently or together to form a robust network architecture.

Using Inmarsat's network of geosynchronous satellites, the IsatData Pro network provides the ability to monitor and control remote Federal Signal sirens. The remote satellite terminal is a rugged external, small form factor design that requires outdoor mounting. The network availability is 99.995%, and the 24/7 Network Operations Center (NOC) provides continuous and reliable service, which is required with these types of mission-critical services.

Figure 1 Satellite Communications

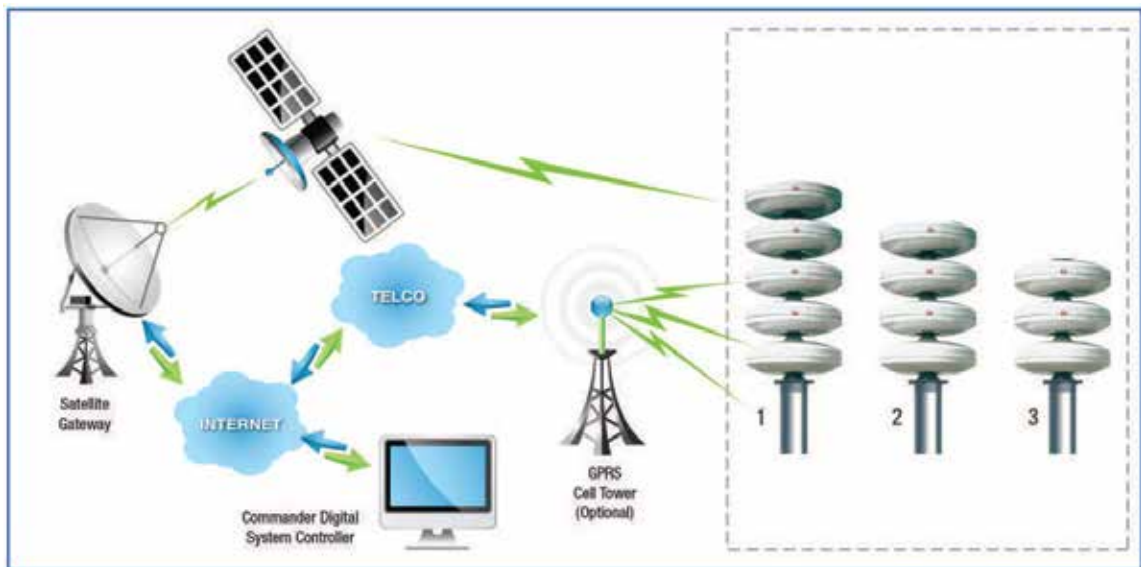

Features

The kit has the following features:

- Two-way communications enabling messaging for monitoring and controlling operations
- Rugged design for use in extreme conditions – NEMA 4X Fiberglass housing
- Compact form factor for easy installation

Ordering Information

Table 1 Ordering Information

Part Numbers	Description
Q-UV-ISAT2	Satellite terminal to the UltraVoice® interface kit, includes cables and mounting hardware
Q-SAT-KIT	Satellite interface cables to read the signal strength for a satellite terminal

NOTE: Upgrade kits can be used on both UV and DC Cabinets.

Qualifications

Intermediate PC skills are required to install and configure this product. IT person is preferred.

NOTE: The UV+ and FC Controller must be flashed for Com 2 Function to be SkyWave IDP.

Specifications

Table 2 Specifications

Size	6.3 x 1.9 inches 160 mm (diameter) x 47 mm (height)
Weight	Approx. 1.1 lb (500 grams)
Operating Temperature	-40°F to 185°F (-40°C to 85°C)
Humidity	95% Relative Humidity at +30°C, non-condensing
Dust and Water Ingress	IP67/NEMA 4X
Frequency	Rx: 1525.0 to 1559.0 Mhz; 32-FSK Tx: 1626.5 to 1660.5 Mhz; 2-FSK
EIRP	9 dBW max
Elevation Angle	0° to 90°
Approvals	Inmarsat D+/IsatM2M Type, Approved, FCC, CE Mark (R&TTE), RoHS, Anate, IEC/EN 60945
Warranty	Fifteen months from the shipment, the manufacturer's warranty

Required Equipment

Required Hardware

You need the following equipment:

- Computer running Windows® 10 or higher with a DB9 RS-232 serial port. A typical USB to serial adapter will work.

The following equipment is provided in the Model Q-SAT-KIT by Federal Signal:

- Six-conductor non-crossover modular data cable (1751134)
- Six-conductor crossover modular data cable (1751004)
- Federal Signal three-way modular adapter (2005204)
- Standard DB9 Null modem (13902678A)

Required Software

You need the following software:

- Skywave Scope software
- Commander® software
- USB Flasher software

Firmware for the UltraVoice® or FC Controller card

Request firmware and where to download the software from Federal Signal Technical Support at 800-524-3021 or 708-534-3400 extension 7329 or through e-mail at techsupport@fedsig.com.

Figure 2 Equipment Included in Model Q-UV-ISAT2

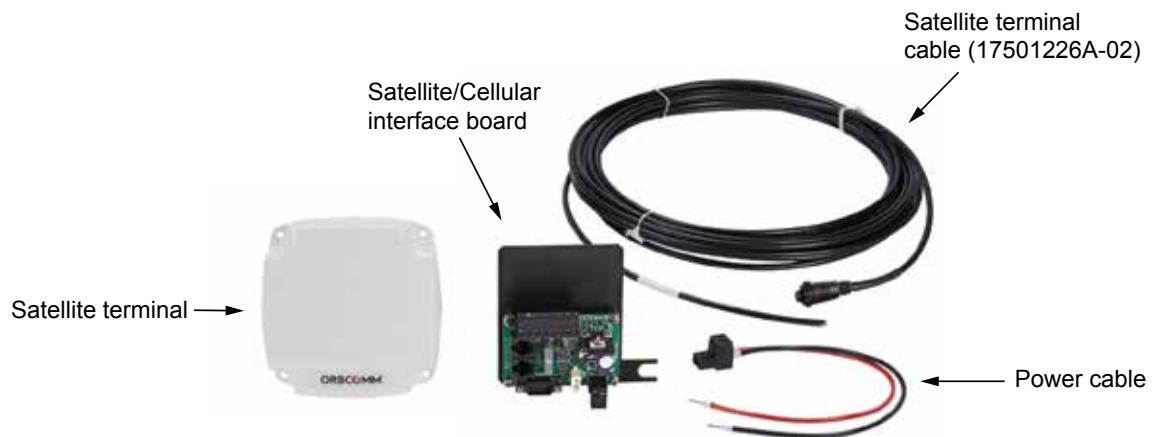

NOTE: Mounting hardware is not pictured.

Satellite Terminal (ST 6100) Required Information

Request the following information from Federal Signal Technical Support.

Table 3 Satellite Terminal (ST 6100) Required Information

SkyWave Terminal ID for each RTU	
Gateway Account Name	
Gateway Account ID	
Access ID	
Broadcast ID	
Password	
Azimuth	
Elevation	

Installing and Configuring the Satellite Terminal (ST 6100)

The following is a typical procedure for installing and configuring the Satellite Terminal (ST 6100). The programming for the Satellite Terminal requires using the USB Flasher software and Commander® software. This procedure uses common configurations.

1. Installing the Satellite Terminal (ST 6100)

To install the Satellite Terminal (ST6100):

- Refer to the ST 6100 Terminal Installation Guide. Request the manual from Federal Signal Technical Support.
- Placement of the Satellite Terminal (ST 6100) is critical for reliable communications. Ensure that there are no trees or other obstructions.

2. Confirming the Wiring Connections

2. Confirming the Wiring Connections

To confirm the wiring connections for the Satellite Terminal (ST 6100), satellite interface board, and UltraVoice® (UV+) Controller card:

1. Confirm the 24 Vdc power cable from the UV+ backplane motherboard at JP13 is connected to the satellite interface board at JP5.

Figure 3 UV+ Backplane Motherboard (JP13)

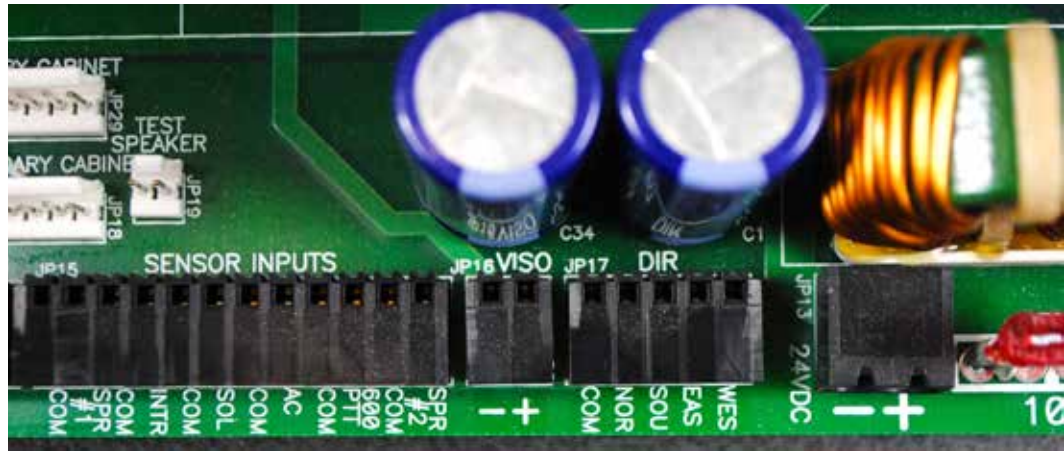

JP13 24VDC

2. Confirm the modular cable from the satellite interface board at JP3 is connected to the UV+ board at RS232-2 (left port).

Figure 4 UV+ Controller RS232-2 (left port)

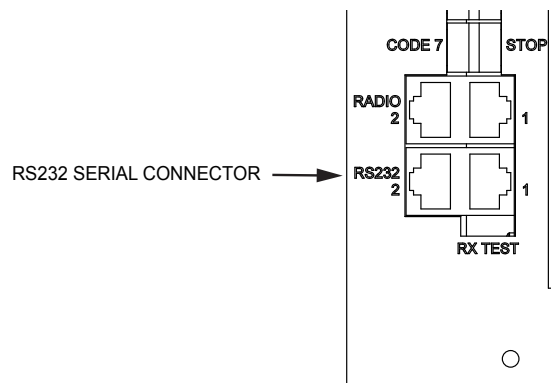

3. Confirm the cable from the Satellite Terminal (ST 6100) is connected to the satellite interface board at JP4.

2. Confirming the Wiring Connections

Figure 5 Wiring Connections from Satellite Terminal to the interface board to UV+ controller card

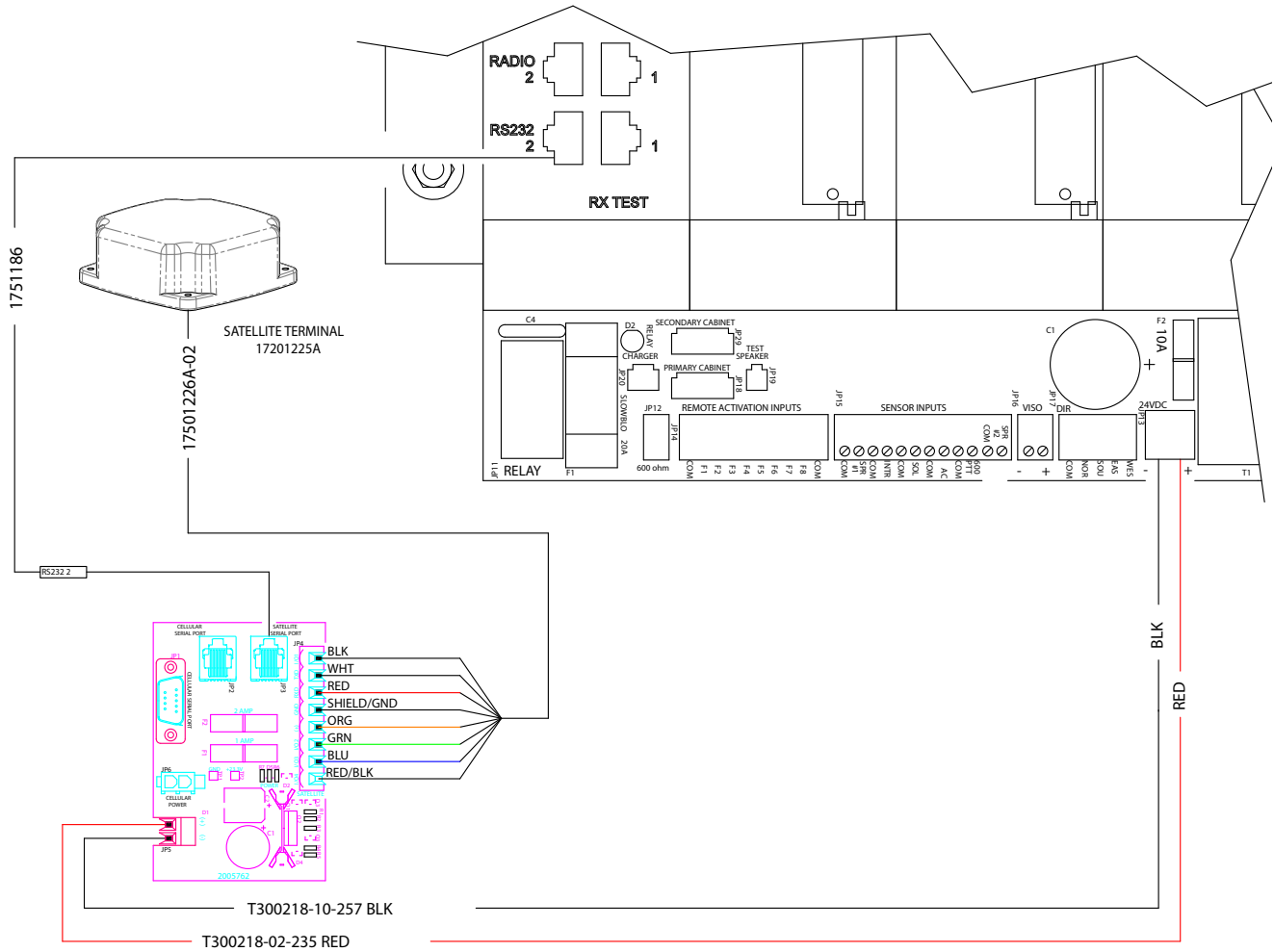

3. Reading the Signal Strength of the Satellite

3. Reading the Signal Strength of the Satellite

To read the Satellite Terminal (ST 6100) using the Q-SAT-KIT:

1. Connect the modular data cable (1751134) to the satellite/cellular interface board at JP3.

Figure 6 Satellite interface board

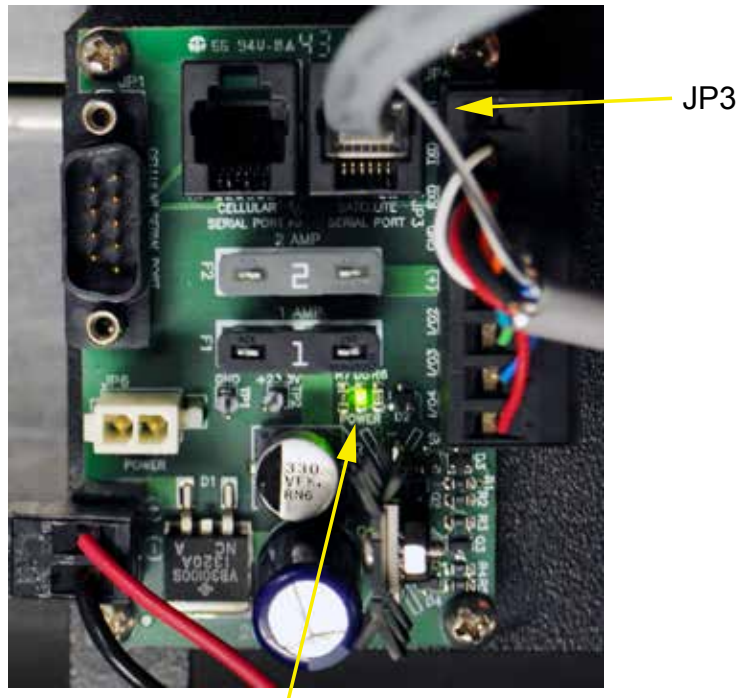

LED illuminated

2. Verify that the power LED is illuminated on the satellite/cellular interface board.

3. Reading the Signal Strength of the Satellite

3. Connect the modular data cable to the computer serial port using the three-way adapter and null modem. See Figure 7.

Figure 7 Modular data cable with the three-way adapter and null modem



4. On your PC, run the Scope software, scroll to ORBCOMM® Developer Toolkit, and select Scope from the Start button on the taskbar.

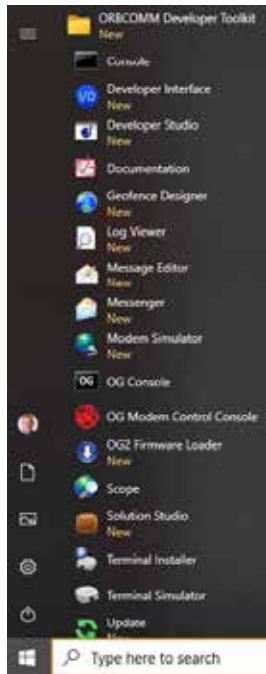

5. Set Timeout to 30 seconds.



6. Select File > Open Connection.

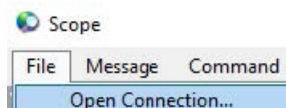

3. Reading the Signal Strength of the Satellite

- On your PC, open Device Manager and select the com port that will be used to communication with the satellite terminal. Click the Port Settings tab and ensure that it is configured for maximum bits per second.

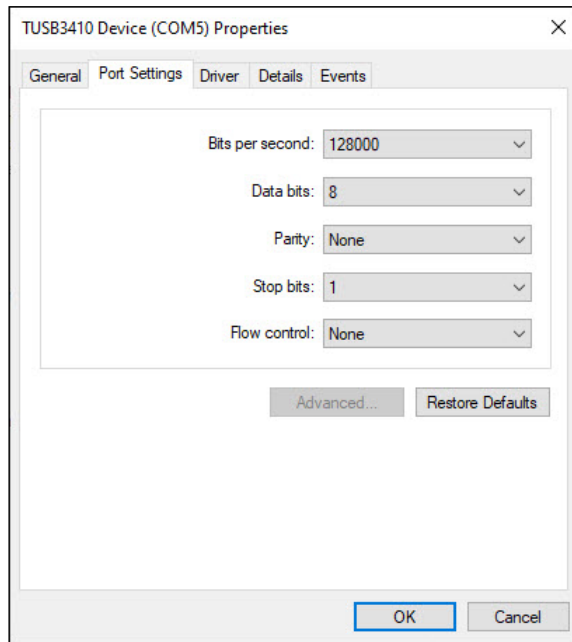

- In the ORBCOMM® software, select the com port that will be used to communicate with the satellite terminal. Select File > Open Connection. The Open Connection dialog box appears.

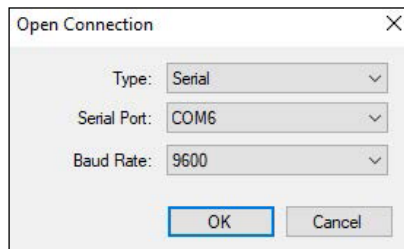

Field	Select
Type	Serial
Serial Port	COMnumber (Com port being used on your PC)
Baud Rate	9600

- Click OK. The following window appears.

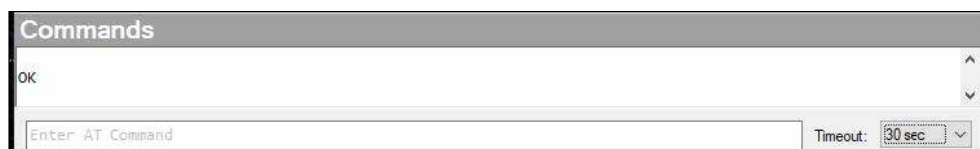

If the connection fails, the following window appears.

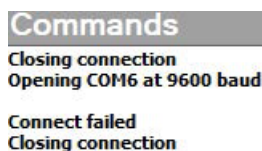

Troubleshooting

Check the following:

- Sometimes the connection fails on the first try, so try again. If it still fails, check all connections, and ensure that the cable type is the six-conductors non-crossover modular data cable (1751134).
 - Is the board powered?
 - Is the com port set correctly in the Device Manager window on your PC?
 - Is bad weather preventing the connection?
10. Verify communication with the terminal by “AT” followed by “OK” when communication is established. Terminal successfully communicated with the program.
 11. Verify that the Satellite status shows active, followed by signal strength. The signal strength should be a minimum of 42 dB for reliable operation. If the level is below 42 dB, review the ST 6100 Installation Guide and pay extra attention to the instruction for pointing the satellite, including the picture showing the 45° rotation. Also, determine if an obstacle is blocking the satellite reception path.

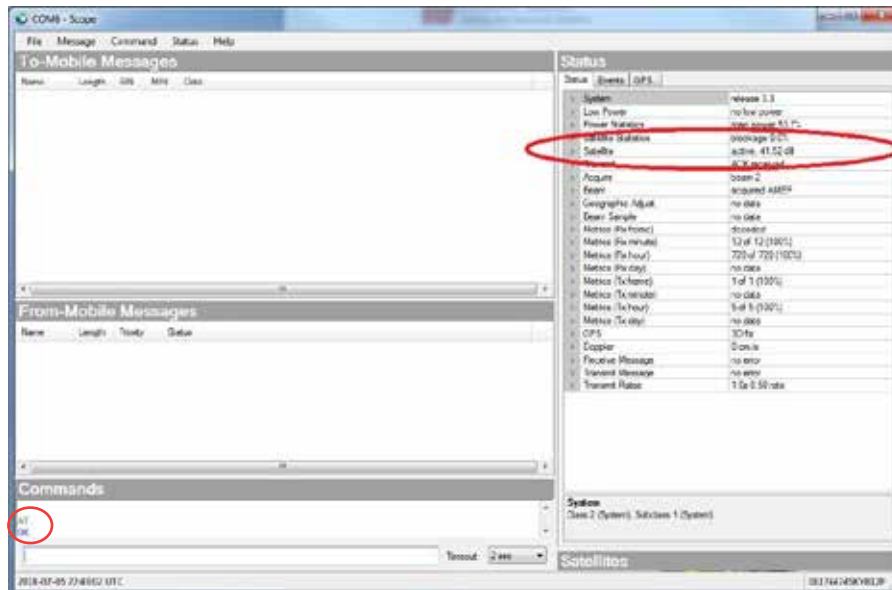

12. Close the ORBCOMM® Developer Toolkit application.
13. Remove the modular data cable (1751134) to the satellite/cellular interface board at JP3. Reinstall the original cable between the controller card RS232 serial port and JP3 on the satellite/cellular interface board. See “Figure 5 Wiring Connections from Satellite Terminal to the interface board to UV+ controller card” on page 13.

4. Determining if using Security Code or Encryption Key

In the Commander® software, determine if you are using Security Code or Encryption Key.

14. Open the Commander® software.
15. From the Commander® main window, click System Setup. The System Setup dialog box appears.
16. Click the Security Keys button on the System Setup dialog box. The Security Keys dialog box appears.
17. Document if using Security Code or Encryption Key. The below example is no Security Code (65535) and no Encryption Key (all zeros).



18. Close Commander® software.

6. Programming the UV+ Controller card for Satellite Mode

If this firmware flash section has already been properly completed, go to “7. Configuring Commander Software for Satellite Mode” on page 25. Typically, this firmware flash section has already been completed at Federal Signal. If you are not sure this was completed, skip this section and come back later if it does not work.

IMPORTANT: Do NOT run Commander® software and USB Flasher software simultaneously on the same PC, as they will compete for the same com port, which will cause a collision.

19. On your PC, run the USB Flasher software; select from the Start button on the taskbar: Start > Federal Signal Corporation > USB Flasher.

20. Select the Com that is being used by selecting Setup > Com Port.

NOTE: If you are not sure which com port is being used on your PC, open Device Manager and confirm the com port. To watch to com port appear, unplug and plug the USB cable.

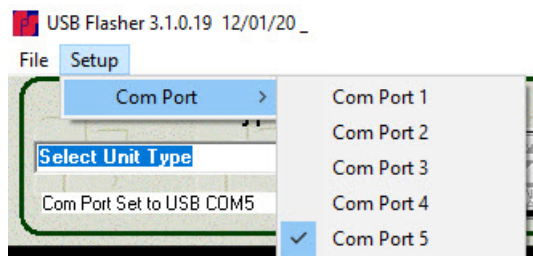

21. Click the Unit Type arrow and select UV+ 5698 Controller in this example.

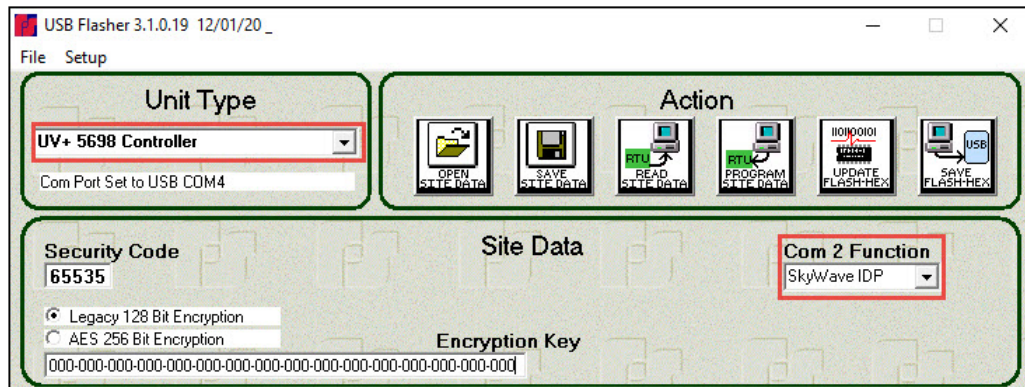

22. Click the Com 2 Function arrow and select SkyWave IDP.

6. Programming the UV+ Controller card for Satellite Mode

26. Select the firmware file for the unit type, and click the Open button. The following example is from the date of writing this document. A newer version is expected.



27. An information dialog box appears.
28. Click OK.

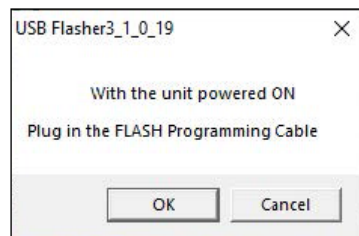

29. The USB Flasher Software displays the progress of the firmware being flashed. An information dialog box appears. Click OK, and close the USB Flasher Software.



6. Programming the FC Controller card for Satellite Mode

If this firmware flash section has already been properly completed, go to “7. Configuring Commander Software for Satellite Mode” on page 25. Typically, this firmware flash section has already been completed at Federal Signal. If you are not sure this was completed, skip this section and come back later if it does not work.

IMPORTANT: Do NOT run Commander® software and USB Flasher software simultaneously on the same PC, as they will compete for the same com port, which will cause a collision.

- 30. On your PC, run the USB Flasher software; select from the Start button on the taskbar: Start > Federal Signal Corporation > USB Flasher.
- 31. Select the Com that is being used by selecting Setup > Com Port.

NOTE: If you are not sure which com port is being used on your PC, open Device Manager and confirm the com port. To watch to com port appear, unplug and plug the USB cable.

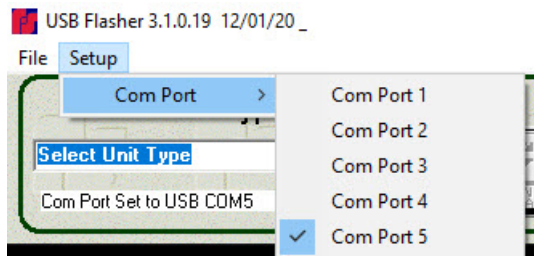

- 32. Click the Unit Type arrow and select FCX 0200 Controller in this example.

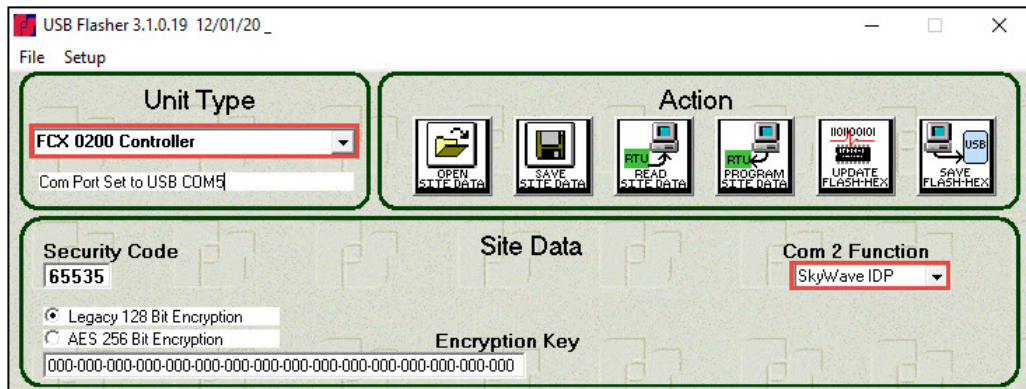

- 33. Click the Com 2 Function arrow and select SkyWave IDP.

6. Programming the FC Controller card for Satellite Mode

34. If the Commander® software had a Security Code or Encryption Key, enter it here before flashing firmware into the FC controller card.

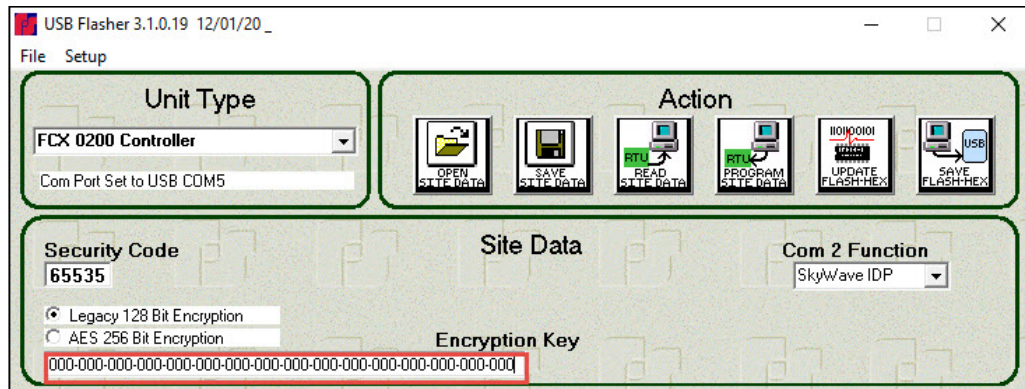

35. Connect the Universal Programmer to the FC controller card. Ensure that the cable is plugged into RS232-1 (right port) on the FC controller board. Ensure that the other end of the cable is plugged into the FLASH port on the Universal Programmer.

Figure 9 Connecting PC, Universal Programmer, and FC controller card

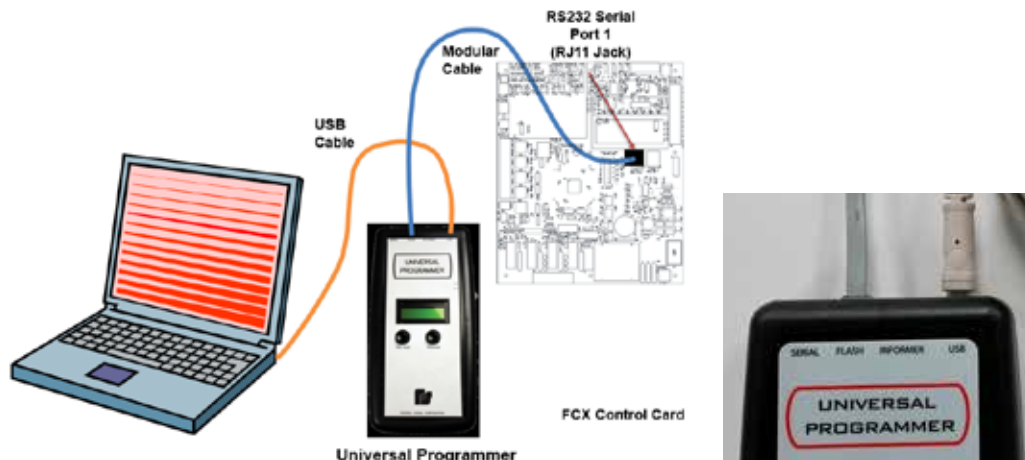

36. Click the UPDATE FLASH HEX button.

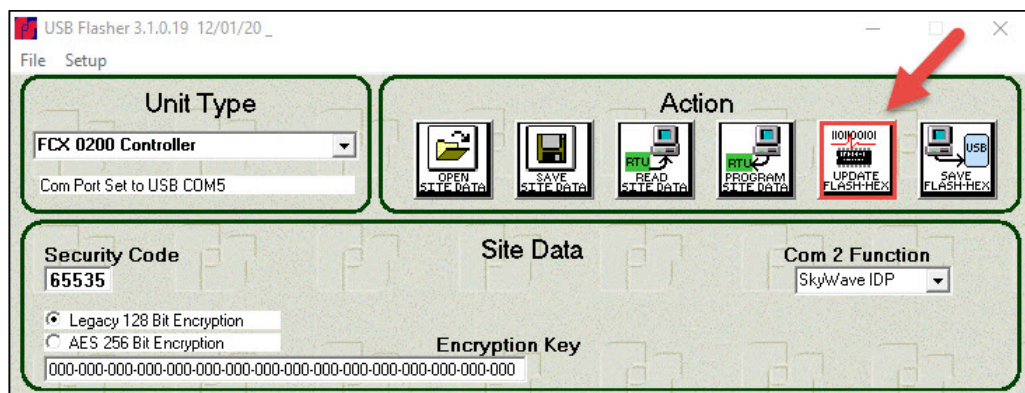

The Open dialog box appears.

6. Programming the FC Controller card for Satellite Mode

37. Select the firmware file for the unit type, and click the Open button. The following example is from the date of writing this document. A newer version is expected.

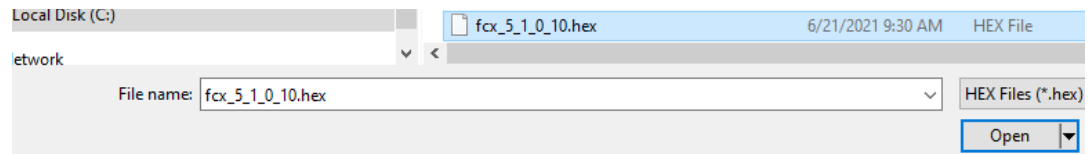

38. An information dialog box appears.
39. Click OK.

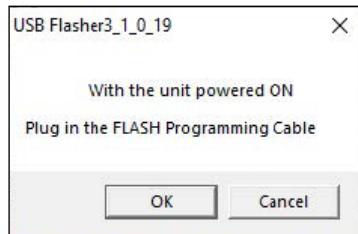

40. The USB Flasher Software displays the progress of the firmware being flashed. An information dialog box appears. Click OK, and close the USB Flasher Software.

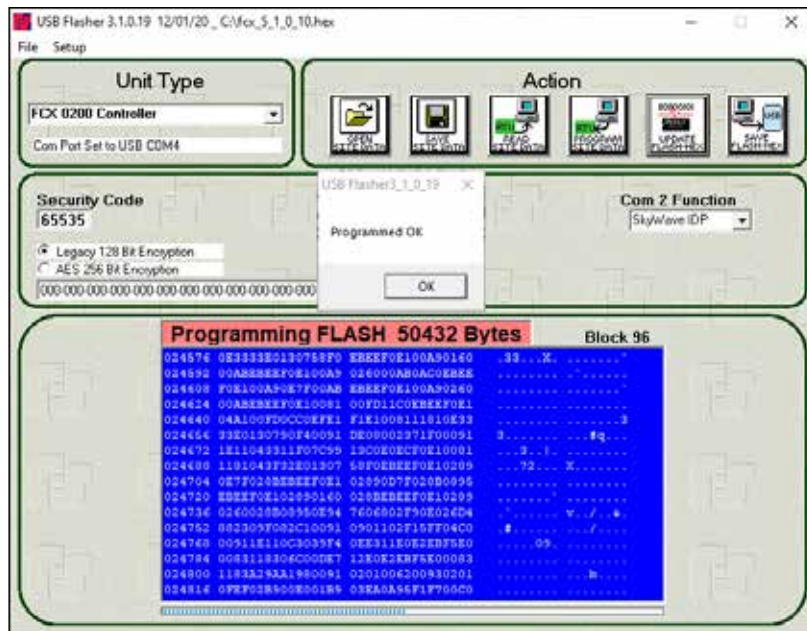

7. Configuring Commander Software for Satellite Mode

To configure Commander® software for satellite mode:

41. Open the Commander® software.
42. From the Commander® main window, click System Setup. The System Setup dialog box appears.
43. In the Mode list, select SkyWave IDP.

NOTE: SkyWave IDP can be configured for any of the four communications channels if using multiple channels for communications.

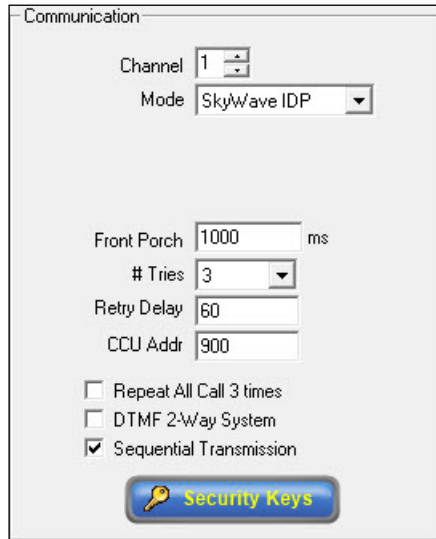

44. From the System Setup main window, click SkyWave Setup.

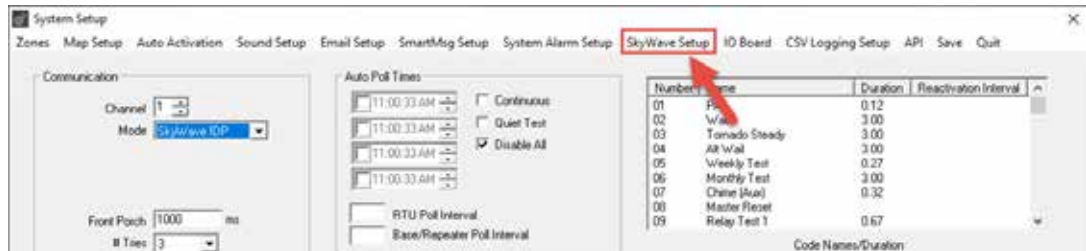

45. The SkyWave Setup dialog box appears.



7. Configuring Commander Software for Satellite Mode

46. In the SkyWave Setup dialog box, enter the satellite information.

Fields	Enter information into the fields
Access ID	Provided by Federal Signal (for example, 00001234)
Password	Provided by Federal Signal (for example, ABCDEFGH)
Broadcast ID	Provided by Federal Signal (for example, 0123456SKYB12F)
Receive Interval	5
Logging Mode	Full

47. Click Save.
 48. Click Save again to get back to the Commander® main window.
 49. From the Commander® main window, click RTU. The RTU dialog box appears.
 50. Select the RTU to configure.



51. Click Configure. The Configure RTU General Parameters dialog box appears.

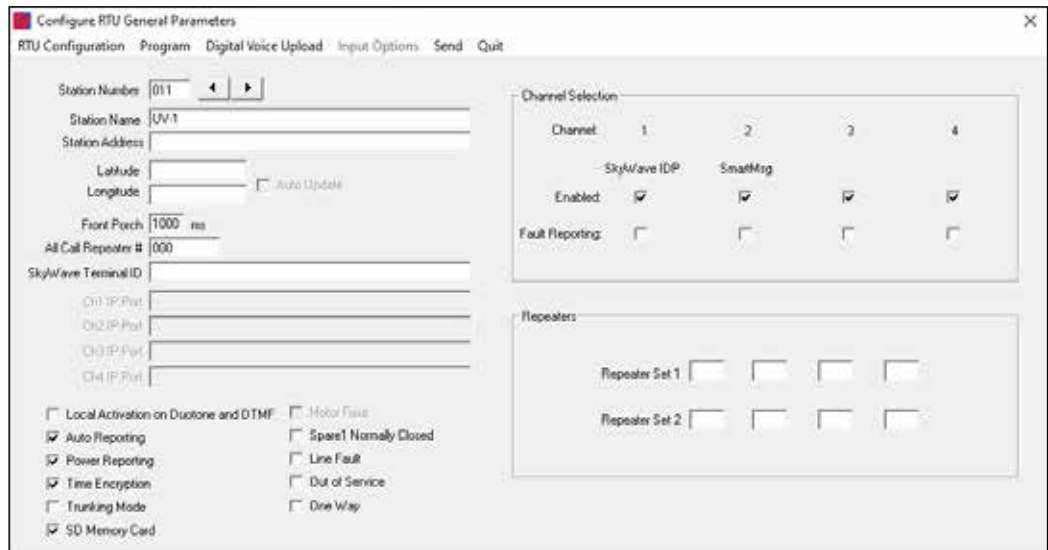

In the Configure RTU General Parameters dialog box, enter the SkyWave Terminal ID provided by Federal Signal.

NOTE: The SkyWave Terminal ID has to be unique for each RTU.

Fields	Description
SkyWave Terminal ID	For systems using SkyWave IDP communication mode, specify the Terminal ID of the SkyWave terminal (for example: 01234567ABCDEF).

52. Click Quit.

53. Select the RTU, and click Poll Selected.

The screenshot shows a web interface for managing RTUs. At the top, there is a navigation bar with buttons: Configure, Status Details, Poll Selected, Poll All, Cancel Poll, Master Reset All, Quiet Test All, Pocsag Reset, Reset Status, and Communication Time. Below the navigation bar is a search section with 'Name' and 'Address' input fields. The main content is a table with the following data:

RTU#	Status	Name	Address	RTU Ver
001	Standby	DCFCTBH	2645 Federal Signal Drive	4.1.0.9
002	Standby	DCFCTBDH	1234 Chicago Ave	5.1.0.10
003	Standby	UVTD_Satellite	5678 University Park	5.2.0.13

A red or green dot indicates good communication. A violet or purple dot indicates the failure of communications.

The UV+ and Commander® setup is complete.

Getting Service

If you are experiencing any difficulties, contact Federal Signal Customer Support at 800-548-7229 or 708-534-3400 extension 7511 or Technical Support at 800-524-3021 or 708-534-3400 extension 7329 or through e-mail at techsupport@fedsig.com. For instruction manuals and information on related products, visit <http://www.fedsig.com>.



FEDERAL SIGNAL
Safety and Security Systems

2645 Federal Signal Drive
University Park, Illinois 60484

www.fedsig.com

Customer Support

800-548-7229 • +1 708 534-3400

Technical Support

800-524-3021 • +1 708 534-3400